

## CREPE MAKERS

*Delicious!*



*Crepes*



*Blinis*



*Mexican Tortillas*



*Buckwheat Pancakes*



*Indian Chapatis*

### CEEB41-120

### CEEB42-208

<b>Power</b>	120V, 1650W, 5-15P	208-240V, 3000W, 6-15P
<b>Cooking surface</b>	15.9"	15.9"
<b>Dim. (L x W x H)</b>	18" x 19" x 5.25"	18" x 19" x 5.25"

\*\* Intended for light commercial use only

*This crepe maker is equipped with a cast-iron plate requiring a seasoning phase before the first use.*

- **Homogeneous cooking:** Equipped with a high temperature and spiral-shaped heating element, directly integrated into the cast iron plate: it heats the cast iron homogeneously.
- **Reinforced insulation:** Counter-plate makes it possible to maintain the temperature over the whole cooking surface without heat loss.
- **High power:** high-performance crepe maker. Capacity of up to 60 crepes an hour!
- **Features:** Thermostat: 110-300°C (230-572°F). Pilot light. Protective wall guard. Wooden spreader included.



Warranty  
(1) year parts and labor

MADE IN FRANCE

# CREPE MAKERS

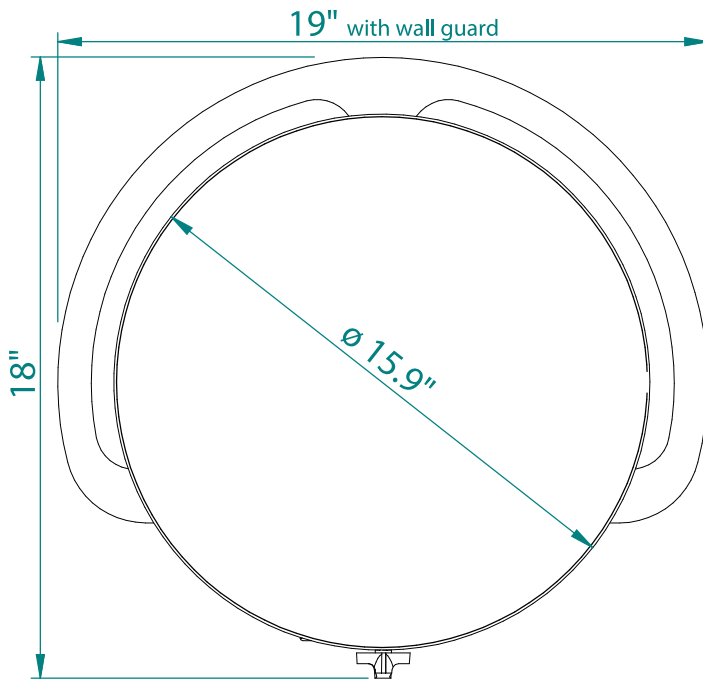
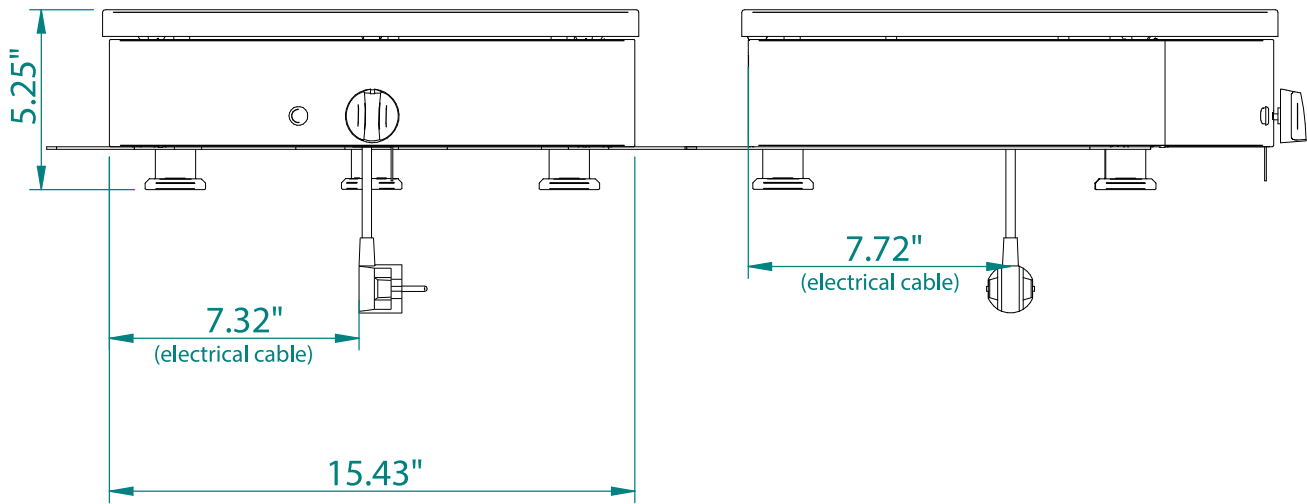

## ELECTRICAL DIAGRAM

