



Model FMS20



Features

Berkel Model FMS20 planetary mixer is a durable, precision crafted machine that is engineered for long-term reliability, convenience and productivity. This versatile, all-purpose mixer uses a powerful, planetary mixing action to thoroughly blend, mix, aerate and knead ingredients for consistent and predictable results. The variable speed motor drive technology eliminates the clutch and allows changing speeds while the mixer is running (EasyShift™). This 20 quart mixer comes standard with a stainless steel bowl, bowl guard, spiral dough hook, batter beater, wire whip and ingredient chute. The innovative “two point” mounting system increases the ease of installing and removing the mixing bowl. The stainless steel bowl guard slides open for adding ingredients, and is easily removed for cleaning. Operator safety interlocks prevent the mixer from running if the bowl guard is removed, opened or the bowl is lowered. The FMS20 has five (5) speed options including a blend speed to control splash out. The FMS20 can be operated in a continuous run mode or by a 15-minute timer that will automatically shut off the machine after the desired processing period has elapsed. The FMS20 features ergonomically designed moisture resistant switches and No-Volt Release.

Approved By: _____
Date _____

Item # _____

Model FMS20

Planetary Mixer

- FMS20 20 Qt. Bench Type Mixer with Hub

Standard Features

- ▶ Model FMS20 20 Qt. Mixer with 5-speed, 1 HP (continuous duty), totally enclosed, and permanently lubricated, thermally protected motor; furnished in 100-120/50/60/1, 11 amp, UL listed.
- ▶ Variable speed motor drive allows EasyShift™ change of mixer speeds without stopping
- ▶ Hardened alloy steel helical planetary gears, fully sealed in lubricant with heavy-duty ball bearings, provide for long-term, dependable operation
- ▶ Blend speed and 4 fixed speeds with slow initial acceleration to prevent product splash-out
- ▶ Simplified “Two Point” bowl mounting allows easy attachment and removal.
- ▶ Manual bowl lift is lever operated, interlocked and self-locking in top position
- ▶ Continuous operation or 15-minute timed operation that automatically shuts off the machine in any speed after pre-determined time has elapsed.
- ▶ Stainless steel bowl, bowl guard, flat batter beater, wire whip, spiral dough hook and ingredient chute included
- ▶ Bowl guard with safety interlocks prevents the mixer from running if guard is opened or removed
- ▶ No-Volt Release prevents automatic re-activation in the event of a power interruption.
- ▶ Bowl guard easily removed for bowl access and cleaning
- ▶ Reliable, moisture resistant stop and start switches
- ▶ Solid cast base is mounted on rubber pads for vibration control and rust resistance. Attractive silver metallic epoxy enamel for easy cleaning
- ▶ 6-foot, flexible, 3-wire power cord and grounded plug
- ▶ #12 taper hub with optional #12 attachments

Options

- 100-120/50/60/1 UL Listed, without hub
- 200-240/50/60/1 UL Listed, with hub

Accessories

- Stainless Steel Bowl
- Batter Beater
- Wire Whip
- Splash Cover
- Spiral Hook
- Bowl Reduction Set
- Ingredient Chute
- FCMC – #12 taper hub meat grinder
- VSPH – #12 taper hub vegetable slicer/grater



Planetary Mixer Model FMS20

Berkel

Model FMS20

Planetary Mixer

Model No.	Bowl Capacity	Product Dimensions		
		Width A	Depth B	Height C
FMS20	20 Qts. (21 Liters)	17¾" (451 mm)	23¾" (591 mm)	31½" (800 mm)

Model No.	Motor	Electrical	Speed Range Beater (RPM)	Weight		Box Dimensions		
				Net	Ship	Width	Depth	Height
FMS20	5-speed 1 HP	100-120/50/60/1	53 - 313 (53, 106, 187, 292, 313)	174 lbs. (79 kg.)	205 lbs. (93 kg.)	30½" (775 mm)	28½" (724 mm)	37¾" (959 mm)

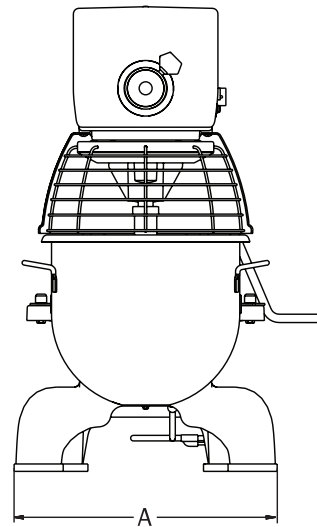
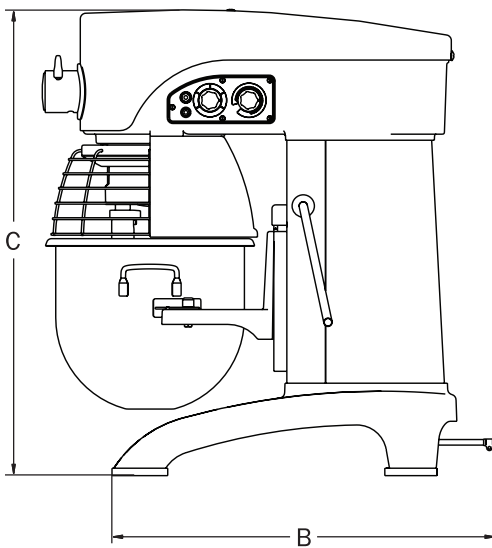

Specifications

Design: Heavy-duty, all purpose mixer uses a powerful, planetary mixing action to thoroughly blend, mix, aerate and knead ingredients with consistent and predictable results.

Motor/Electrical: Model FMS20 20-Qt. Mixer with 5-speed, 1 HP (continuous duty), totally enclosed, and permanently lubricated, thermally protected motor; furnished in 100-120/50/60/1, 11 amp, UL listed.

Finish/Construction: Cast base finished in metallic silver, epoxy enamel for easy cleaning.

Planetary Gears: Hardened alloy steel, helical gears fully sealed in lubricant with heavy-duty ball bearings for highly dependable, quiet operation.

Speeds: "Blend" speed and 4 fixed speeds with slow initial acceleration.

Bowl Guard: Stainless steel bowl guard with interlock prevents the mixer from running if guard is opened or removed. Guard is slideable for adding ingredients and removable for cleaning.

Bowl: Simplified "two point" mounting provides easy attachment and removal of bowl.

Power Hub: #12 taper hub for use with FMS20 #12 optional attachments.

Controls: Moisture resistant, conveniently located controls include ergonomically designed on-off switch, a 5-speed selector switch, and a 15 minute timer.

No-Volt Release: Prevents activation of the mixer in the event of a power interruption; operator must restart the mixer.

Standard Equipment: The mixing unit with one stainless steel bowl, bowl guard, flat batter beater, wire whip, spiral dough hook and ingredient chute.

Bowl Lift: Manual bowl lift is lever operated and self-locking in top position.

Cord and Plug: Attached 6-foot flexible 3-wire cord and plug for grounded receptacle on 100-120/50/60/1.

Warranty: All parts, service and travel coverage for one year, exclusive of wear items.

As we continually strive to improve our products, specifications are necessarily subject to change without notice.

**Berkel Company • 2006 Northwestern Parkway • PO Box 696 • Louisville, KY 40201
800-348-0251 • FAX 888-888-2838 • www.berkel.com**