

REFRIGERATOR MANUFACTURER
Turbo air
 more durable, efficient, beautiful

4184 E. Conant St.
 Long Beach, CA 90808
 Tel. 310-900-1000
 Fax. 310-900-1077
www.turboairinc.com

Project :	
Model # :	
Item # :	Qty :
Available W/H :	
Approval :	

Worktop Freezer

Worktops
 Super Deluxe Series

3 YEAR PARTS & LABOR WARRANTY

Model : TWF-60SD



FEATURES / BENEFITS

- STAINLESS STEEL CABINET CONSTRUCTION**
 The Turbo Air Super Deluxe model boasts a stainless steel interior and exterior (galvanized steel back & bottom). It guarantees the utmost in cleanliness and long product life. The Super Deluxe can add a touch of style to the most refined setting.
- EFFICIENT REFRIGERATION SYSTEM**
 Turbo Air's solid door freezers are designed with oversized and balanced (CFC Free R-134A, R-404A) refrigeration systems. These include efficient evaporators and condensers for faster freezing and greater efficiency.
- STURDY, CLEAN STAINLESS STEEL SHELVING**
 Shelves are the most important part of cleanliness as they come in direct contact with food. After a while, PVC coated wire shelves may peel, rust and lead to unsanitary conditions. Only the Turbo Air Super Deluxe series uniquely provides stainless steel shelving.
- HIGH-DENSITY POLYURETHANE INSULATION**
 The entire cabinet structure and solid doors are foamed-in-place using high density, CFC free polyurethane insulation.
- HOT GAS CONDENSATE SYSTEM**
 Through Turbo Air's creative innovation, the condensate system surfaces have been specially treated to resist corrosion. This not only increases efficiency without the risk of refrigerant leakage from corrosion, but also prevents the overflow of condensate water.
- ERGONOMICALLY DESIGNED DOORS**
 Customers' fatigue fades away with easy grip handles and doors that open effortlessly. These features along with self-closing doors make this the ultimate choice in customer convenience. ABS sheet door liners resist water condensation with thermal efficiency.
- MAGNETIC DOOR GASKETS**
 Magnetic door gaskets are of one piece construction, removable without tools for ease of cleaning and replacement.
- INCANDESCENT INTERIOR LIGHTING**
- FREEZER HOLDS -5°F ~ -10°F FOR THE BEST IN FROZEN FOOD PRESERVATION**



Model	Swing Door	CU./FT.	#of Shelves	HP	AMPS	Crated Weight (lbs.)	L x D* x H† (inches)
TWF-60SD	2	16	2	1/2	9	293	60 1/4 x 30 x 33 1/2

Model : TWF-60SD

ELECTRICAL DATA	
Voltage	115/60/1
Plug Type	 NEMA-5-15P
Full Load Amperes	9
Compressor HP	1/2
Cord Length ft.	9
Refrigerant	R-404A
DIMENSIONAL DATA	
Net Capacity cu. ft.	16
Ext. Length Overall in.	60 1/4 (1530mm)
Ext. Depth Overall in.*	30 (762mm)
Ext. Height Overall in.†	33 1/2 (851mm)
# of Doors	2
# of Shelves	2
Gross Weight lbs.	293
Net Weight lbs.	254

Design and specifications subject to change without notice.

Actual shipping weight may differ due to extra packing materials for product protection.

* Depth does not include 1" for rear spacers.

† Height does not include 5-7/8" for caster height.

■ **WARRANTY : 3 Year Parts and Labor Warranty
Additional 2 Year Warranty on Compressor**

- SELF-CONTAINED SYSTEM
- STANDARD 4" SWIVEL CASTERS WITH LOCKS ON THE FRONT SET
- 2.5" DIA. CASTERS AVAILABLE
- 1/2" DIAMETER & 13 TPI (OPTIONAL)
- LEGS AVAILABLE FOR ALL MODELS (OPTIONAL)

■ **OPTIONAL ACCESSORIES :**

- 2.5" Diameter casters
- 5" Diameter casters
- 6" ABS plastic legs
- Additional stainless steel shelves
- Additional PE coated wire shelves

PLAN VIEW

(unit : inch)

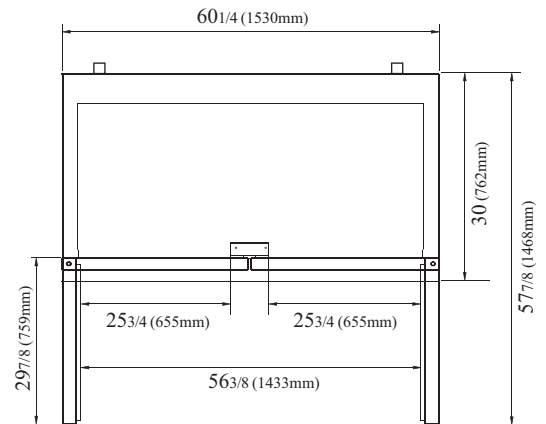

PLAN VIEW

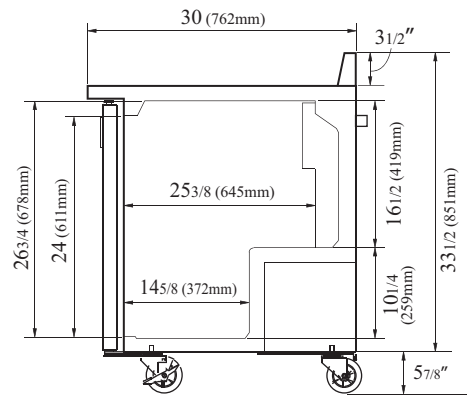

SIDE VIEW

Ver.201401



- Turbo Air : 800-627-0032
- GK : 800-500-3519
- Warranty : 800-381-7770
- AC : 888-900-1002