

Only from Nemco!

## The New and Improved Fresh-O-Matic by Nemco

Instantly reclaim all the freshness and flavor of your precooked and frozen foods with one simple push of a button!



**NOTICE**  
AFTER PREHEAT (20 MINUTES), GREEN "READY" LIGHT TURNS ON INDICATING UNIT IS READY. DURING USE THE RED "STANDBY" LIGHT WILL FLASH INDICATING THE TEMPERATURE IS RECOVERING & STEAMER CANNOT BE USED.  
NOTE THAT THE CONTROL WILL NOT ALLOW THE STEAMER TO PUMP WATER MORE THAN TWICE EVERY 30 SECONDS.  
WATER FILL OPERATION: GREEN TOP "FULL" LIGHT - WATER IS AT MAXIMUM CAPACITY. DO NOT ADD WATER. GREEN TOP "LOW" LIGHT - WATER IS AT LOW LEVEL. ADD WATER - STEAMER WILL NO LONGER WORK. WHEN RED "EMPTY" LIGHT IS BLINKING, ADD WATER - STEAMER WILL NO LONGER WORK.

**UPDATED!**  
Controls  
& Indicator Lights  
for more reliability  
and convenience!

Manufactured  
In The USA 

# This Is Not Your Father's Fresh-O-Matic!

Instantly thermalize precooked or frozen baked foods, meats, seafood, veggies, pasta and more with the reliable and super easy-to-use Fresh-O-Matic by Nemco.

## Restore Food Quality to "Fresh-Made" Goodness.

Fresh-O-Matic's super-hot steam instantly returns moist heat to cold precooked day-old foods.

- Meats regained their just-sliced texture and juiciness.
- Buns and baked goods return to fresh-from-the-oven flakiness and flavor.
- Refrigerated precooked vegetables burst with garden-fresh flavor and color in seconds.

## Turn the Novice Into an Expert

Just push the button to deliver precisely the right measure of steam to thermalize or rethermalize foods to their original chef-prepared greatness. Anyone can do it!

- Just plug it in, and add distilled water.
- NEW! Flashing red light means it's getting ready.
- NEW! Solid green light means GO!
- NEW! Steam button steams but will not permit flooding of the heater plate.
- Easy-to-see water-level indicator.



## Rely on Superior Durability

If it has "by Nemco" at the end of its name, you know it's built for long life and maximum return on your investment.

- Heavy-duty stainless steel outer wrap stands up to the most demanding kitchen environments.
- Compact portable design fits about anywhere on the kitchen counter.
- NEW! Sealed, high-heat-resistant water reservoir is seamless—has no welded tank that might eventually leak.
- WearGuard™ coated tray liner delivers lasting performance and makes cleanup fast and easy.

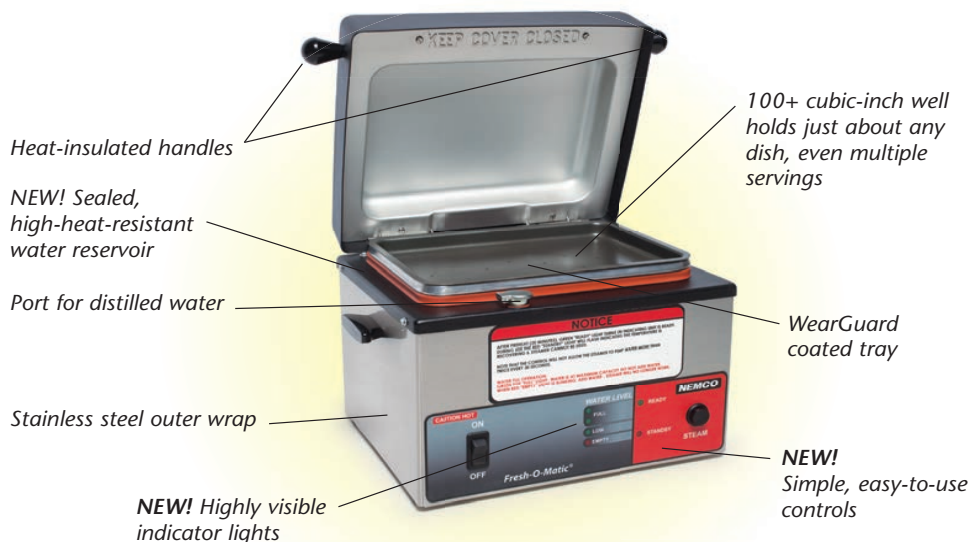

## Suggested Uses

Instantly introduces super-heated steam to return stale baked goods, meats, veggies, pasta and sandwiches to fresh-as-new goodness! Works great with about any cold, precooked and even day-old foods like blueberry muffins, beef stew or lobster dinners. Ideal for Mexican burritos—flour or corn tortilla shells. If it's left-over or frozen, Fresh-O-Matic can make it taste freshly cooked again.

## General Specifications

For Model No: 6625B

### Dimensions

Equipment (w x d x h)	16½" x 12" x 11⅝"
Equipment weight	34.6 lbs.
Shipping weight	40.0 lbs.

## Performance Specifications

Preheat time	20 minutes
Capacity (pan w x d x h)	11¼" x 7¼" x 1¼"
Controls	Push-button switch controls steam

## Electrical Requirements

Voltage	120V
Wattage	1,500W
Amps	12.5 amp @ 120V
Power cord	120V: NEMA 5-15P

Replacement parts are available through Nemco's 24-hour Zip Program.

Nemco reserves the right to make design, specification or model changes without notice.



**NEMCO**  
FOOD EQUIPMENT

"Exceeding your expectations"

Nemco® Food Equipment, Ltd.  
301 Meuse Argonne  
Hicksville, Ohio 43526  
1.800.782.6761  
419.542.7751  
419.542.6690, fax  
www.nemcofoodequip.com

Printed 5/14. Printed in the U.S.A.



FOOD EQUIPMENT

## Operating and Maintenance Instructions

### Model: 6625B Fresh - O - Matic® Food Steamer

#### **INTRODUCTION**

1. Please read instructions before using this appliance.
2. When using electrical appliances, basic precautions should always be followed to reduce the risk of fire, electric shock and injury.
3. Clean machine thoroughly before and after all uses following cleaning instructions below.

#### **ELECTRICAL REQUIREMENTS**

Plug steamer into a grounded outlet with correct voltage and sufficient power capacity. Refer to the product label (serial plate) on the Fresh-O-Matic® for voltage and wattage requirements.

#### **SAFETY INSTRUCTIONS**

1. **Warning!** All power must be disconnected at power source before any service procedure is performed.
2. This appliance is hot when in use. To avoid burns, do not let bare skin touch hot surfaces. Keep combustible materials, such as drapes and other furnishings, away from appliance.
3. Extreme caution is necessary when any appliance is used by or near children and whenever the appliance is left unattended.
4. Always unplug appliance when not in use and before cleaning, adjusting or maintaining this machine. To disconnect appliance, turn controls off and remove plug from power source.
5. Do not operate any appliance with a damaged cord or plug, after the appliance malfunctions, has been dropped, or damaged. Return appliance to an authorized service facility for examination, electrical or mechanical adjustment, or repair.
6. Do not use outdoors. This appliance is not intended for use in wet or moist locations. Never locate appliance where it may fall into water.
7. Connect to properly grounded outlets only. Avoid the use of extension cords. Do not run cord under carpeting, runners, or the like. Arrange cord away from traffic area and where it will not be tripped over.
8. This appliance is equipped with a power cord with a three-blade plug. Plug **ONLY** into a matching three-blade outlet. **DO NOT** cut or break off the third blade or attempt to use with a two-blade extension cord.
9. To prevent a possible fire, it is recommended that the unit is placed on a non-combustible surface.
10. This appliance has electrical parts. Do not use it in areas where gasoline, paint, or flammable liquids are used or stored.

#### **PREPARATION**

1. Set Fresh-O-Matic® on a flat stable surface, near the power source.
2. Clean Fresh-O-Matic® thoroughly before use.
3. If unit fails to work properly when first operated call NEMCO customer service at 1-800-782-6761.

#### **OPERATION**

1. Plug CORD into grounded electrical outlet of the correct voltage. Electrical shock can occur if appliance is not grounded.
2. Turn power on using the rocker switch. The steamer will be in "STANDBY" mode until the heater plate is fully heated. Pre-heating will take approximately 20 minutes.
3. Lift "Snap Cap."
4. Fill water tank with only **DISTILLED WATER** until the top "FULL" water level light is illuminated (approximately 4-1/2 quarts).  
Note: Do not use De-Ionized or Reverse Osmosis water. Refill as necessary - being sure to stop when the top green light is illuminated. **DO NOT OVERFILL.** A funnel may be used, with care.  
**NOTE: IF WATER LEVEL LIGHTS FAIL TO WORK WHEN THE TANK IS INITIALLY FILLED, SLOWLY ADD TAP WATER TO THE TANK UNTIL THE LIGHTS BEGIN TO WORK. ADD UP TO 1 CUP OF TAP WATER - DO NOT OVERFILL.**
5. There is approximately 1/2 quart of water in the tank when the "LOW" light is on. The steam button may be used while the "LOW" light is on. The "EMPTY" light will blink when the tank is empty and the steamer will not function properly until filled.
6. Fresh-O-Matic® is ready for use when the "READY" light becomes solid green.
7. Lift cover; place food to be served in the Fresh-O-Matic®.
8. Close cover; press Steam Button two (2) times approximately every 30 seconds. Note: Each push of the steam button releases approximately 10 cc's (1/3 ounce) of steam/water. See "Cooking Options" for complete instructions. **NOTE: The controls will only allow the Fresh-O-Matic® to steam twice every 30 seconds.**
9. When first filling the Fresh-O-Matic®, the steam button may need to be pressed multiple times in order to prime the water pump.
10. Open cover; food is hot, ready to serve.

**NOTE:** It is important to keep Fresh-O-Matic® cover closed between uses so that proper temperature is maintained for maximum efficiency. The cover must be closed to visually see steam and hold steam.

NEMCO FOOD EQUIPMENT 301 Meuse Argonne, Hicksville, OH 43526  
Phone: (419) 542-7751 Fax: (419) 542-6690 Toll free: 1-800-782-6761  
[www.nemcofoodequip.com](http://www.nemcofoodequip.com)

## **CLEANING**

**NOTE: Proper maintenance plays an important part in the life span and functioning of the unit. To maintain appearance and increase the service life, the unit should be cleaned at least daily.**

### **Daily Cleaning**

1. Unplug the power cord and let unit cool before cleaning or moving.
2. Lift out removable aluminum food tray. Clean thoroughly.
3. Brush out crumbs in the food tray compartment.
4. Remove cover. Clean thoroughly.
5. Wipe food tray casting with damp cloth.
6. If necessary, scour food tray casting with a nylon soap pad. Wipe casting clean.
7. Wipe exterior with damp cloth. Do not use scouring powders or abrasive cleaners on switch pad.
8. Put cover back on.

**NOTE:** Before using for first time each day, pre-heat Fresh-O-Matic ® and press the steam button twice every 30 seconds for a few minutes to free any particles that may be in the steam vent holes; wipe away the particles and the Fresh-O-Matic ® is ready for use.

### **Occasional Cleaning**

**CAUTION:** While cleaning the unit, care should be given to avoid water contact with the control pad. Water should never be allowed to enter the electronic controls compartment of this equipment. If you believe this has happened with your unit, call your local authorized service agent for repair. Never attempt to use or repair if it has become contaminated with water.

1. Unplug the power cord and let unit cool before cleaning or moving.
2. Move the unit to the edge of a sink, with the back of the unit slightly over the edge of the sink.
3. Remove the hose clamp and drain cap.
4. Allow the water to drain from the tank and filter. Tip the unit slightly to remove the most water.
5. Replace the drain plug.
6. Refill the tank, flush and drain again, if necessary.
7. Replace the drain plug and hose clamp.

## **COOKING OPTIONS**

### **Main Dishes**

Fresh-O-Matic ® serves hundreds of steaming-hot convenience foods, from beef to lobster dinners. And Fresh-O-Matic ® by Nemco is more than a single-portion speed merchant. It heats two to four servings just as fast - with the same tasty results.

Canned Entrees - 3-4 minutes  
 Refrigerated or Thawed Entrees - 4-5 minutes (stir at 2-1/2 minutes)

	<b>HEATING TIME</b>	
	<b>From Room Temperature</b>	<b>From Refrigerated State</b>
Rice	45 seconds	60-90 Seconds
Spaghetti	90 seconds	2 minutes
Buttered Noodles	90 seconds	2 minutes

The following charts are a guide to heating various foods in your Fresh-O-Matic ®. Place food on disposable aluminum foil plate or tray. Press steam button twice and repeat every 30 seconds according to the time indicated below.

### **PRE-COOKED MEATS, FISH, POULTRY: REFRIGERATED**

	<b>HEATING TIME</b>
	<b>From Refrigerated State</b>
*Bacon	60 to 75 seconds
Boiled Shrimp	1 to 1-1/2 minutes
Diced Crab Meat	1 to 1-1/2 minutes
*Roast Meats: Very Thin Sliced	45 to 60 seconds
Thin Sliced	1 to 1-1/2 minutes
Thick Sliced	2 to 2-1/2 minutes
Diced Chicken or Turkey	2 minutes
Crab Legs	2-1/2 to 3 minutes
**Hamburger Patties, Cube Steaks, Salisbury's	2 to 3-1/2 minutes
Lobster Tails	3 to 4 minutes
Wiener's	3-1/2 minutes
Sloppy Joes	3-1/2 minutes
Meat Loaf	3-1/2 minutes

\* Warm or Room Temperature will take less time.

\*\* For cheeseburger, add slice of cheese for the last 30 seconds.

**NEMCO FOOD EQUIPMENT** 301 Meuse Argonne, Hicksville, OH 43526  
 Phone: (419) 542-7751 Fax: (419) 542-6690 Toll free: 1-800-782-6761  
[www.nemcofoodequip.com](http://www.nemcofoodequip.com)

**BAKED GOODS - FRESH, ROOM TEMPERATURE (Longer time for refrigerated)**

	<b>HEATING TIME</b>
	<b>From Room Temperature</b>
*Open Hamburger and Wiener Buns	15 seconds
*Coffee Cake	15 to 30 seconds
*Pancake	15 to 30 seconds
Fruit and Nut Breads, sliced	20 to 45 seconds
*Corn Bread	30 to 45 seconds
*Dinner Rolls	30 to 60 seconds
*Muffins	30 to 60 seconds
*Biscuits	45 to 90 seconds
Sweet Rolls	1 to 2-1/2 minutes
Pizza	1-1/2 to 2 minutes
**Fruit Pie, wedges	2 minutes

\* Place directly on perforated aluminum tray.

\*\* Press steam button twice right away; at 30 seconds press steam button twice more; do not give any more steam for the remainder of the time.

**HORS D'OEUVRES**

To freshen the bread in cold prepared hors d'oeuvres, place in Fresh-O-Matic ® for 15 seconds.

**SANDWICHES**

Heat meat and buns as directed and then assemble sandwich.

The following charts are a guide to heat various food in your Fresh-O-Matic ®. Place food on disposable aluminum foil plate or tray. Press steam button twice and repeat every 30 seconds according to time indicated below.

**PRE-COOKED FRUITS AND VEGETABLES (CANNED OR ROOM TEMPERATURE)**

	<b>HEATING TIME</b>
	<b>From Canned or Room Temperature</b>
*Water Packaged Vegetables	2 minutes
*Creamed Vegetables	3 to 3-1/2 minutes
Glazed Pineapple Ring	1-1/2 minutes
Glazed peach Half	2 to 2-1/2 minutes
Applesauce	2-1/2 to 3 minutes

\* Refrigerated cooked vegetables will take approximately 30 seconds longer.

**GRAVY AND SAUCES**

	<b>HEATING TIME</b>
	<b>From Canned or Room Temperature</b>
Maple Syrup	50 to 90 seconds
**Hot Cocktail or Chili Sauce	1-1/2 minutes
**Hot Fudge Sauce	2 minutes
Refrigerated Gravy	2-1/2 to 4 minutes

\*\* Hot Fudge And Chili Sauce may be heated in paper souffle cups but will take longer.

**EGGS**

Poached - 60 to 75 seconds

Break egg in lightly greased individual foil dish; place in Fresh-O-Matic ® and press steam button two (2) times; at 30 seconds press the steam button twice more. For eggs with soft whites, do not give any more steam. For firm egg whites, give two more presses of steam at 60 seconds. Both types may take the full 75 seconds.

Scrambled - 60 to 75 seconds

Pour scrambled egg mixture into lightly greased disposable foil tray; place in Fresh-O-Matic ® and give two (2) presses of steam; at 30 seconds give two (2) more presses of steam; at 45 seconds stir gently. For very moist eggs do not give any more steam. For dry eggs give two (2) presses of steam at 60 seconds. Both types of eggs may take longer than 60 seconds.

**SERVICE INSTRUCTIONS**

**Repair: To avoid serious injury or damage, do not repair the unit or replace a damaged power cord yourself. Repairs must be coordinated through: NEMCO Food Equipment customer service at 1-800-782-6761.**

PROBLEM	REASON	SOLUTION
No Steam	<ul style="list-style-type: none"> <li>• Air in line</li> <li>• Power not on</li> <li>• Water level low</li> <li>• Unit will only steam twice every 30 seconds</li> <li>• Water level too low.</li> <li>• Holes have become "plugged"</li> </ul>	<ul style="list-style-type: none"> <li>• Heat unit, continue to press steam button as steamer will allow until air is forced out.</li> <li>• Turn on power.</li> <li>• Fill unit with distilled water.</li> <li>• Allow for time – Wait until "READY" light is lit and push button again.</li> <li>• Fill unit with distilled water.</li> <li>• Clean and use perforated tray only.</li> </ul>
Water Under Unit	<ul style="list-style-type: none"> <li>• Overfilling or tipping the unit.</li> <li>• Condensation from under the cover.</li> </ul>	<ul style="list-style-type: none"> <li>• Do not overfill or tip unit.</li> <li>• Check hose connections and secure, if necessary.</li> </ul>
Water On Plate	<ul style="list-style-type: none"> <li>• Pressing steam button to often or holding down the steam button.</li> </ul>	<ul style="list-style-type: none"> <li>• Allow 30-second between each demand for steam.</li> </ul>
Water Level Lights not Lighting	<ul style="list-style-type: none"> <li>• Distilled water is too pure for water level sensors to sense.</li> </ul>	<ul style="list-style-type: none"> <li>• Slowly add tap water to reservoir until lights begin to work – add up to 1 cup of tap water</li> </ul>

**6625B. FRESH-O-MATIC FOOD STEAMER**

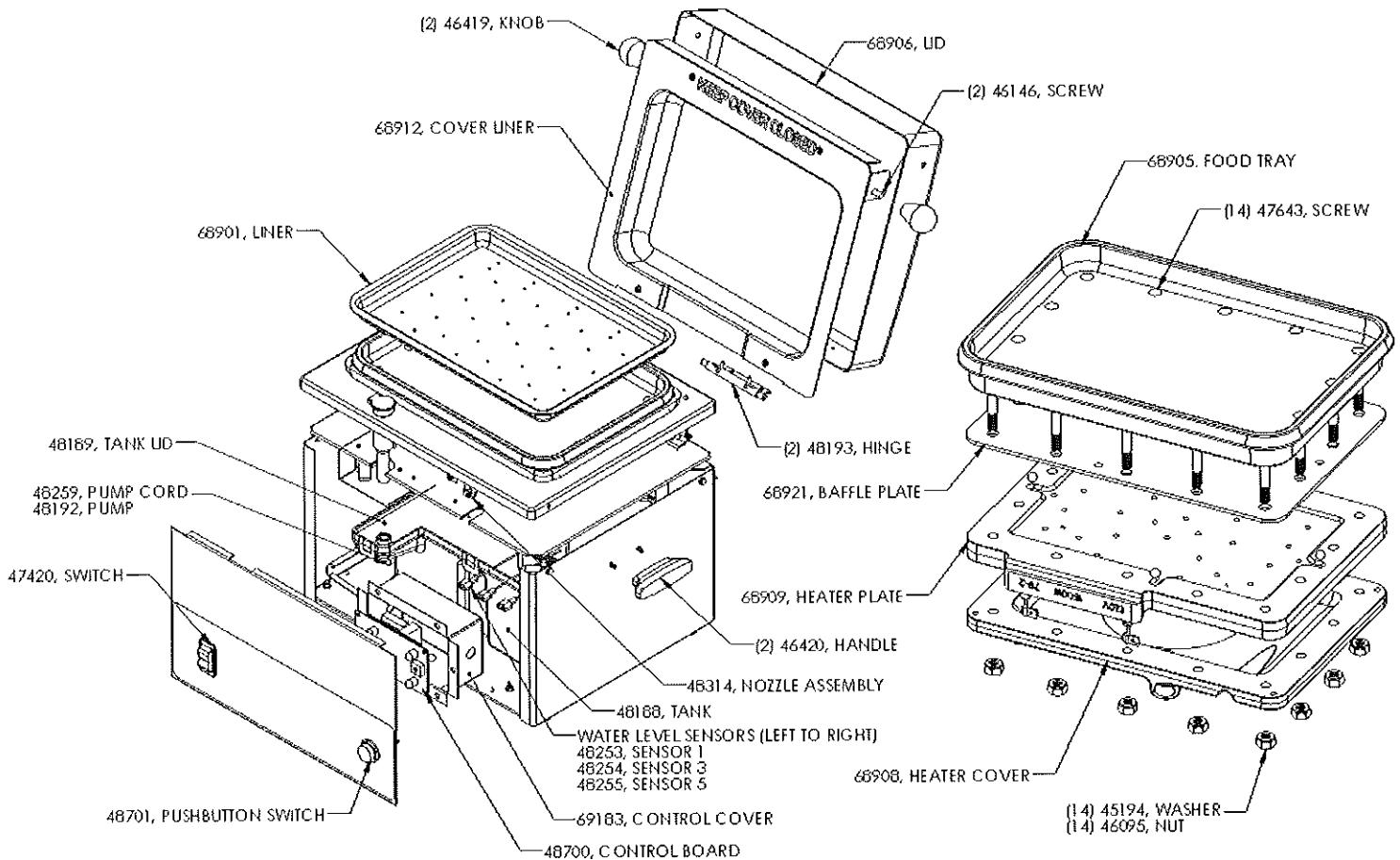

Model	Volts	Amps	Watts	Hz	Phase
6625B	120	12.5	1500	60	1



**NEMCO FOOD EQUIPMENT** 301 Meuse Argonne, Hicksville, OH 43526  
 Phone: (419) 542-7751 Fax: (419) 542-6690 Toll free: 1-800-782-6761  
[www.nemcofoodequip.com](http://www.nemcofoodequip.com)