



X Series 36" Gas Restaurant Range

Item: _____
 Quantity: _____
 Project: _____
 Approval: _____
 Date: _____

X Series 36" Gas Restaurant Range

Models:

- X36-6R X36-6S X36-2G24R X36-2G24S



Model X36-6R

NOTE: Ranges supplied with casters must be installed with an approved restraining device.

Standard Features:

- Large 27" (686mm) work top surface
- Stainless steel front and sides
- Stainless steel 4" (102mm) plate rail
- Stainless steel backguard w/ removable stainless steel shelf
- 12" (305mm) section stamped drip trays w/ dimpled bottom
- Durable easy to read control knobs
- Easy to clean 6" (152mm) steel core, injection molded legs
- Pressure regulator, 3/4" NPT
- Straight steel tube oven burner 33,000 Btuh/9.67 kW
- Standard size Sunfire oven w/ ribbed porcelain oven bottom and door interior, aluminized top, sides and back
- Oven thermostat w/ Low to 500° F (260° C)
- Nickel plated oven rack with two fixed position oven rack guides
- Heavy duty oven door w/keep-cool handle
- Cabinet base in lieu of oven

Standard on Applicable Models:

- Ergonomic split cast iron top ring grates
- 30,000 Btuh/ 8.79 kW 2 piece cast iron "Q" style donut open burner
- 5/8" (15mm) thick steel griddle plate w/manual hi/lo valve control
- 4-1/4" (108mm) wide grease trough
- 18,000 Btuh/5.27 kW cast iron "H" style griddle burner per 12"(305mm) width of griddle
- Griddle plates only available on right side of range

Optional Features:

- Hot top 12" (305mm) plate, 5/8" (15mm) thick in lieu of two open burners, manual valve controlled w/18,000 Btuh/5.27 kW cast iron burner; standard on left side
- Low profile 9-3/8" (238mm) backguard stainless steel front and sides
- Additional oven racks
- 6" (152mm) swivel casters (4), w/ front locking
- Celsius temperature dials

Specifications:

Gas restaurant series range with standard size Sunfire oven. 35-7/16" (900mm) wide with a 27" (686mm) deep work top surface. Stainless steel front, sides and 4"(102mm) wide front rail. 6" (152mm) legs with adjustable feet. Six robust 2 piece 30,000 Btuh/8.797 kW (Natural gas), cast open burners set in split cast iron ergonomic grates. Griddle or optional hot top with cast iron "H" style burners, 18,000 Btuh/5.27 kW (natural gas), in lieu of open burners. Porcelain oven bottom and door liner. Two position fixed rack guide w/one oven rack. Heavy duty oven door with "keep cool" door handle. Straight steel tube oven burner 33,000 Btuh/9.67 kW (natural gas) provides quality bake and good recovery . Oven thermostat ranges from Low to 500° F (260° C). Available with storage base in lieu of oven.



Garland Commercial Ranges Ltd.
 1177 Kamato Road,
 Mississauga, Ontario
 L4W 1X4 CANADA

General Inquiries 1-905-624-0260
 USA Sales, Parts and Service 1-800-424-2411
 Canadian Sales 1-888-442-7526
 Canada or USA Parts/Service 1-800-427-6668





X Series 36" Gas Restaurant Range

Model Number	Description	Total BTU/Hr Natural	Shipping Information		
			Lbs.	Kg	Cu. Ft.
X36-6R	Six Open Burners w/26" Oven	213,000	430	195	37
X36-6S	Six Open Burners w/Storage Base	180,000	310	141	37
X36-2G24R	24" Griddle, Two Open Burners w/26" Oven	129,000	495	225	37
X36-2G24S	24" Griddle, Two Open Burners w/Storage Base	96,000	375	170	37

Width	Depth	Height w/shelf	Oven Interior			Combustible Wall Clearance		Entry Clearances	
			Height	Depth	Width	Sides	Rear	Crated	Uncrated
35-7/16" (900mm)	33-1/2" (851mm)	57" (1448mm)	13" (330mm)	22" (559mm)	26-1/4" (667mm)	14" (356mm)	6" (152mm)	37" (940mm)	36-1/2" (927mm)

Gas input ratings shown for installations up to 2000 ft.,(610m) above sea level. Please specify altitudes over 2000 ft.

Note: Installation clearance reductions are applicable only where local codes permit.

This product is not approved for residential use.

Burner Ratings (BTU/Hr/kW)			
Gas Type	Open Top	Griddle/ Hot Top	Standard Oven
Natural	30,000/8.79	18,000/5.27	33,000/9.67
Propane	26,000/7.61	18,000/5.27	29,000/8.50

Manifold Operating Pressure	
Natural	Propane
4.5" WC 11 mbar	10" WC 25 mbar

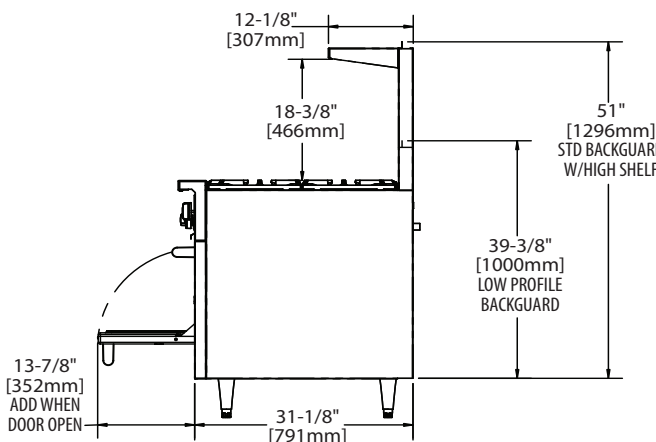
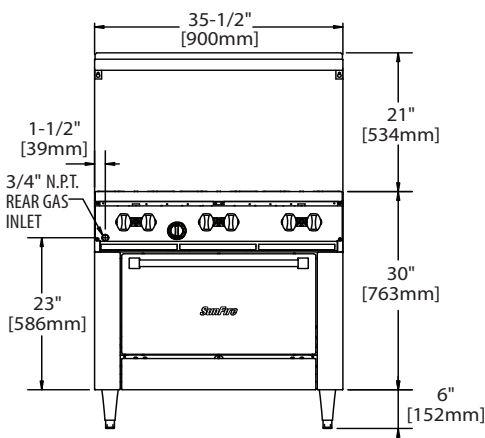
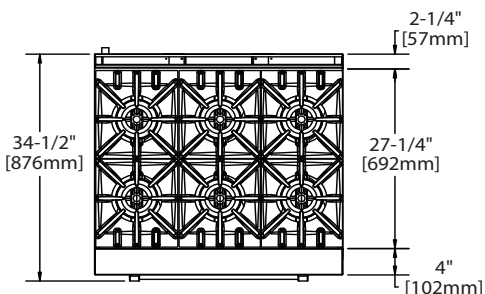

Form# X36 Series (04/26/12)

Garland Commercial Ranges Ltd.
1177 Kamato Road,
Mississauga, Ontario
L4W 1X4 CANADA

General Inquiries 1-905-624-0260
USA Sales, Parts and Service 1-800-424-2411
Canadian Sales 1-888-442-7526
Canada or USA Parts/Service 1-800-427-6668

