

Thermal Carafe Automatic Coffee Brewer

ITEM#

PROJECT

DATE



CWTF15-TC

(no warmers) (thermal carafe sold separately)
 Dimensions: 17.9" H x 9" W x 18.5" D
 (45.5cm H x 22.9cm W x 55.4cm D)

Features

12 Cup Automatic Coffee Brewer

- Brews 3.8 to 7.5 gallons (14.4 to 28.4 litres) of perfect coffee per hour.
- Accepts thermal carafe up to 8.5" tall (21.6cm).
- Use in quick turn environment where high quality coffee is continuously refreshed.
- Models are space saving 9" wide (22.9cm).
- All stainless steel construction.
- Hot water faucet on all models but CW15-TC
- SplashGard® funnel deflects hot liquids away from the hand.
- Pourover feature.

For current specification sheets and other information, go to www.bunn.com.

International models may vary in appearance.

Related Products

Easy Clear® EQ-17-TL

Product No. : 30200.1000
 Dimensions:
 12 $\frac{7}{16}$ " H x 2 $\frac{1}{2}$ " W x 3" D
 31.6 cm H x 6.35 cm W x 7.62 cm D



Thermal Carafe

Product No. : 36029.0001
 Dimensions: 8"H x 6.4"W x 8.2"D
 (20.3cm H x 16.3cm W x 21cm D)



Thermal Carafe (orange lid)

Product No.: 36252.0001
 Dimensions: 8"H x 6.4"W x 8.2"D
 (20.3cm H x 16.3cm W x 21cm D)



Paper Filter Pack

Product No. : 20115.0000
 Packed per case: 1,000
 Dimensions: 4 $\frac{1}{4}$ " Base x 2 $\frac{3}{4}$ " Sidewall
 10.8 cm Base x 6.98 cm Sidewall



Model

Agency Listing

CW15-TC



CWTF15-TC



CWTF20-TC



CWTF-TC DV



Dimensions & Specifications

Model	Product #	Volts	Amps	Tank Heater Watts	Total Watts	Brewing Capacity	Cubic Measure	Shipping Weight	Cord Attached
CW15-TC*	23001.0040	120	11.4	1320	1370	3.9 gal./hr.	5.0 ft ³	28 lbs.	Yes**
CWTF15-TC	12950.0360	120	11.4	1320	1370	3.9 gal./hr.	4.4 ft ³	32 lbs.	Yes**
CWTF20-TC	12950.0380	120	15.4	1800	1850	5.3 gal./hr.	4.6 ft ³	31 lbs.	No
CWTF35-TC	12950.0379	120/ 208-240	15	3500	3550	7.5 gal./hr.	4.4 ft ³	32 lbs.	No
CWTF-TC DV	23001.0069	120	15.4	1800	1850	5.3 gal./hr.	3.7 ft ³	29 lbs.	No
		120/208	11.4	2700	2750	7.5 gal./hr.	3.7 ft ³	29 lbs.	No
		120/240	13.1	3120	3170	7.5 gal./hr.	3.7 ft ³	29 lbs.	No

* No Hot Water Faucet **Power cord (NEMA 5-15P) 15 Amp-120V machine only.

Brewing capacity: based upon incoming water temp of 60°F/15°C (140°F/60°C rise) per 1/2 gallon brew time of 4 minutes.

Models listed as 120/208V or 120/240V must be connected to 208V or 240V electrical service respectively. Please refer to the installation manual.

Electrical: If wired for 120V, requires 2-wires plus ground service rated 120V, single phase, 60 Hz. If wired for 120/208V or 120/240V, requires 3-wires plus ground service rated 120/208V or 120/240V, single phase, 60 Hz.

Plumbing: 20-90 psi (138-621 kPa). Machine supplied with 1/4" male flare fitting.

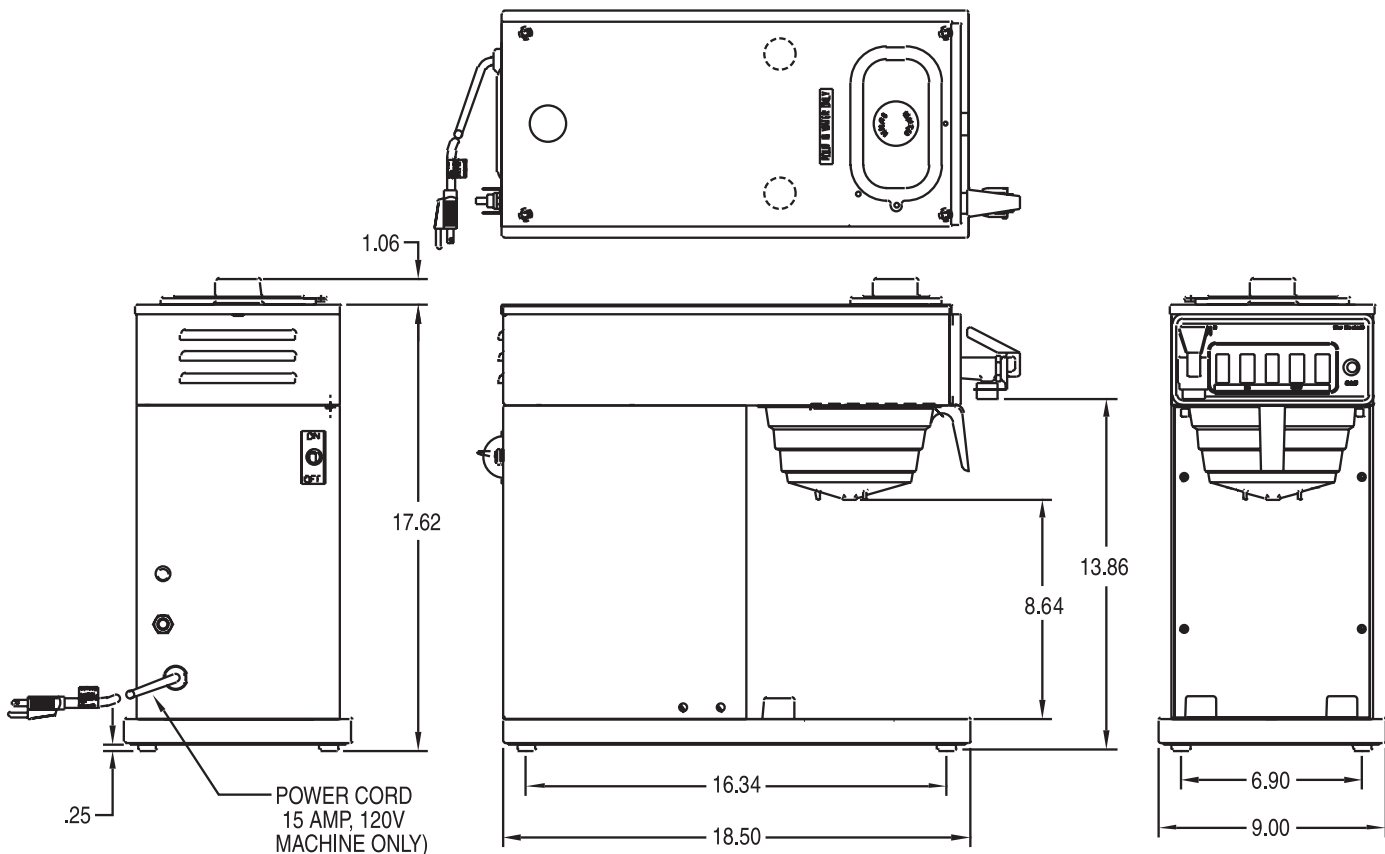

Bunn-O-Matic Corporation - 1400 Stevenson Drive Springfield, Illinois 62703 • 800-637-8606 • 217-529-6601 • Fax 217-529-6644 • www.bunn.com

BUNN® practices continuous product research and improvement. We reserve the right to change specifications and product design without notice. Such revisions do not entitle the buyer to corresponding changes, improvements, additions or replacements for previously purchased equipment.

All dimensions shown in inches.

4/12 © Bunn-O-Matic Corporation