



COUNTER MODEL ACHIEVER HOT PLATE

WOLF RANGE COMPANY



Model AHP424

BASIC MODELS:

AHP212 12" wide	AHP424 24" wide
AHP636 36" wide	AHP848 48" wide

KEY FEATURES:

- Stainless steel sides and control panel
- Full width pull out crumb tray
- Heavy duty cast iron top grates
- 30,000 BTU/hr open burners with lift-off heads
- Standing pilot ignition system
- One infinite heat control valve for each burner
- 6" adjustable legs
- 3/4" rear gas connection and gas pressure regulator

OPTIONAL FEATURES:

- Step-up burners. Rear burners elevated 4".
- Half hot-top on rear burner, 15,000 BTU/hr input.
- 7-5/8", 10", 12" and 13" legs
- Stainless steel stand with undershelf and casters

EXTERIOR DIMENSIONS:

_____ " W x 33" D x 12-3/8" working height on 6" adjustable legs

CLEARANCES:

	Combustible	Non-Combustible
Rear	6"	0"
Sides	6"	0"



CSA design certified. NSF listed.

Approved by _____

Date: _____

**SPECIFY TYPE OF GAS WHEN ORDERING.
SPECIFY ALTITUDE WHEN ABOVE 2,000 FT.**

WOLF RANGE COMPANY

Wolf Range Company
Division of ITW Food Equipment Group LLC
(800) 366-9653
www.wolfrange.com

MODEL: Counter Model Achiever Hot Plate



COUNTER MODEL ACHIEVER HOT PLATE

INSTALLATION REQUIREMENTS:

1. A gas pressure regulator sized for this unit is included. Natural Gas 5.0" W.C. Propane Gas 10.0" W.C.
2. An adequate ventilation system is required for commercial cooking equipment. Information may be obtained by writing to the National Fire Protection Association, 1 Batterymarch Park, Quincy, MA 02169, www.NFPA.org. When writing refer to NFPA No. 96.
3. These units are manufactured for installation in accordance with National Fuel Gas Code, ANSI-Z223.1/NFPA #54 (latest edition). This shall include but not be limited to: NFPA #54 Section 10.3.5.2 for Venting. Copies may be obtained from The American Gas Association Accredited Standards Committee Z223, @ 400 N. Capital St. NW, Washington, DC 20001 or the Secretary Standards Council, NFPA, 1 Batterymarch Park Quincy, MA 02169-7471
4. This appliance must be installed with a 6" clearance at both sides and the rear adjacent to combustible construction.

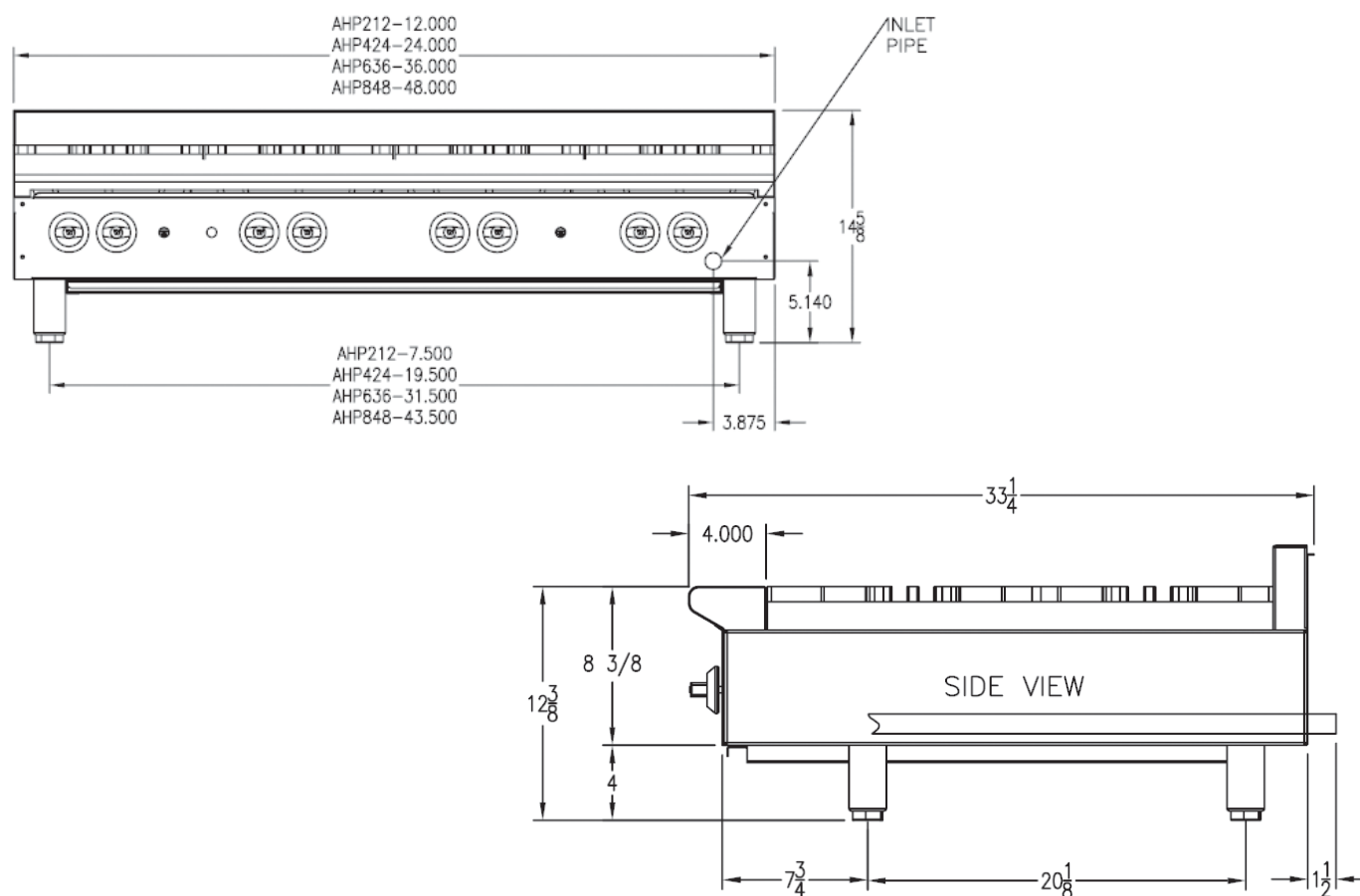

MODEL	WIDTH	DEPTH	OVERALL HEIGHT	WORKING HEIGHT	NO. OF BURNERS	TOTAL BTU/HR.	APPROX. SHIP WT. (LB/KG)
AHP212	12"	33"	14-5/8"	12-3/8"	2	60,000	95 lbs./43 kg
AHP424	24"				4	120,000	165 lbs./74 kg
AHP636	36"				6	180,000	265 lbs./119 kg
AHP848	48"				8	240,000	310 lbs./140 kg

NOTE: In line with its policy to continually improve its product, Wolf Range Company reserves the right to change materials and specifications without notice.
This appliance is manufactured for commercial use only and is not intended for home use.