



# STOCKPOT RANGES

**WOLF RANGE COMPANY**



Model WSPR2F



CSA design certified. NSF listed.

**BASIC MODELS:**

- WSPR1**      One section, 18" wide x 24.5" deep
- WSPR2**      Two sections, 36" wide x 24.5" deep
- WSPR2F**    Two sections, 18" wide x 49" deep

**KEY FEATURES:**

- Stainless steel front and sides. Legs finished in black epoxy powdercoat paint.
- Heavy cast iron top grate(s).
- Two concentric 55,000 BTU/hr ring-type burners per 18" section; 110,000 BTU/hr input per section.
- Standing pilot ignition system.
- Two infinite heat control valves per section.
- Heat shield to protect control valves.
- 3/4" rear gas connection and gas pressure regulator per section (only one for WSPR2F).
- One year limited parts and labor warranty.

**OPTIONAL FEATURES:**

- Stainless steel legs.

**INSTALLATION REQUIREMENTS:**

1. A gas pressure regulator sized for this unit was included. Natural Gas 5" W.C., Propane Gas 10" W.C.
2. Gas line connecting to appliance must be 3/4" diameter or larger. If flexible connectors are used, the inside diameter must be the same as the 3/4" pipe.
3. An adequate ventilation system is required for commercial cooking equipment. Information may be obtained by writing to the National Fire Protection Association, 1 Batterymarch Park, Quincy, MA 02169, [www.NFPA.org](http://www.NFPA.org). When writing refer to NFPA No. 96.
4. These units are manufactured for installation in accordance with National Fuel Gas Code, ANSI-Z223.1/NFPA #54 (latest edition). This shall include but not be limited to: NFPA #54 Section 10.3.5.2 for Venting. Copies may be obtained from The American Gas Association Accredited Standards Committee Z223, @ 400 N. Capital St. NW, Washington, DC 20001 or the Secretary Standards Council, NFPA, 1 Batterymarch Park Quincy, MA 02169-7471.
5. Clearances:

	Combustible	Non-Combustible
Rear	24"	4"
Sides	18"	0"

Approved by \_\_\_\_\_

Date: \_\_\_\_\_

**SPECIFY TYPE OF GAS WHEN ORDERING.  
SPECIFY ALTITUDE WHEN ABOVE 2,000 FT.**

**WOLF RANGE COMPANY**

Wolf Range Company  
Division of ITW Food Equipment Group LLC  
(800) 366-9653  
[www.wolfrange.com](http://www.wolfrange.com)

**MODEL: Stockpot Ranges**



# STOCKPOT RANGES

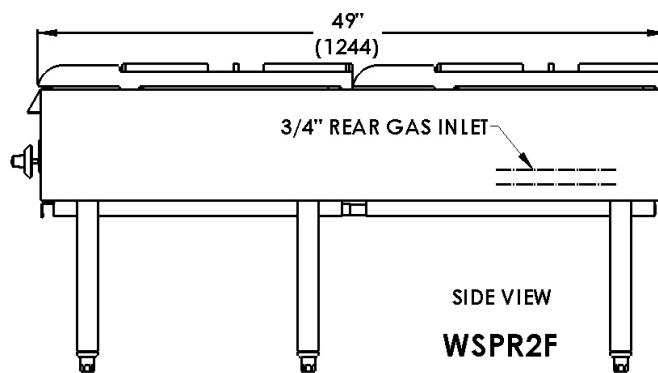
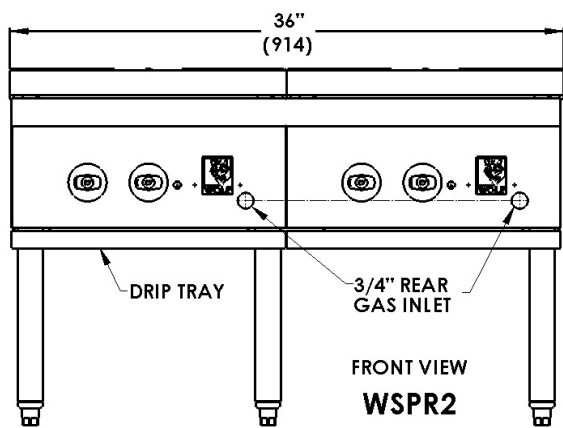
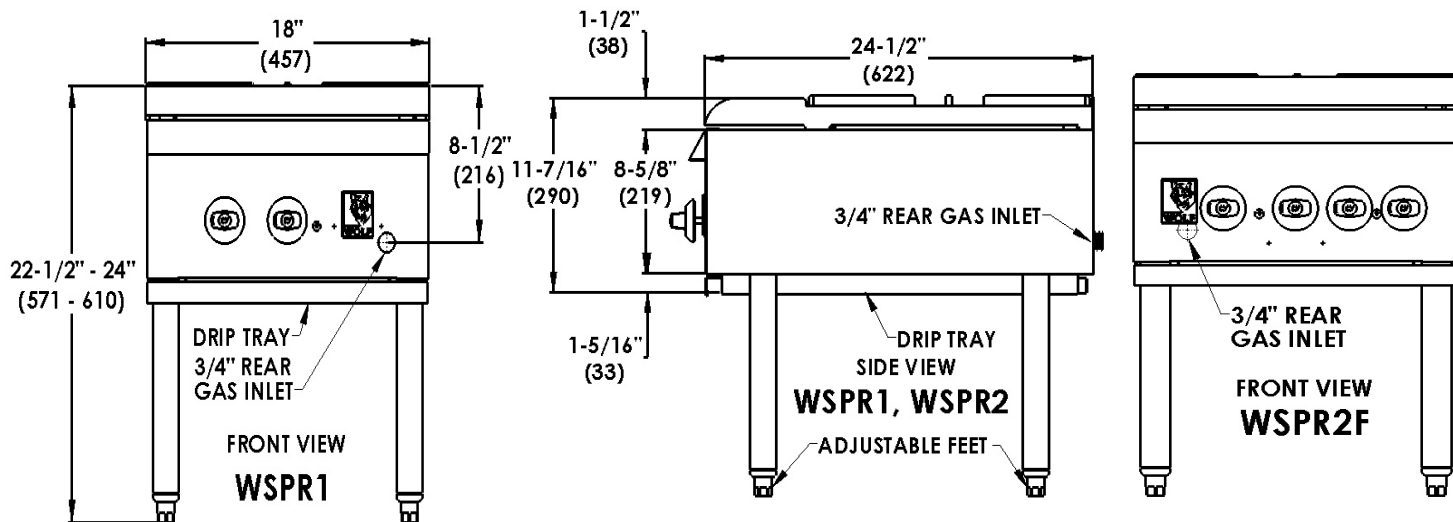

MODEL	TOTAL BTU/HR.	WIDTH	DEPTH	HEIGHT	APPROX SHP WT (LB/KG)
WSPR1	110,000	18"	24 1/2"	22 1/2" to 24"	160/72
WSPR2	220,000	36"	24 1/2"	22 1/2" to 24"	290/131
WSPR2F	220,000	18"	49"	22 1/2" to 24"	290/131

**NOTE:** In line with its policy to continually improve its product, Wolf Range Company reserves the right to change materials and specifications without notice.  
 This appliance is manufactured for commercial use only and is not intended for home use.