



NEMCO STEAMER
Model Series: 6600
OPERATING INSTRUCTIONS

INTRODUCTION

1. Read These Operating Instructions thoroughly before installing or using this Equipment. Improper installation or use can result in equipment or property damage, electric shock or personal injury.
2. Nemco Steamers are heavy duty and are designed for commercial use.
3. Only trained personnel should operate this equipment.

SAFETY INSTRUCTIONS

1. IMPORTANT: Clean machine thoroughly before first use and after all uses, using cleaning instructions below.
2. IMPORTANT: Incoming power MUST be the same as the equipment's rating. Refer to the Electrical Ratings listed on the equipment's Data Tag Located on the side of the unit.
3. CAUTION: This unit's power cord is equipped with a GROUNDED, 3-prong power cord. Plug only into a matching, grounded outlet. DO NOT cut or break off the third prong. Operating this equipment without proper grounding may result in electric shock.
4. CAUTION: Always disconnect Power when not in use and before cleaning or servicing.
5. CAUTION: Do not operate with a damaged cord or plug or after the machine malfunctions, has been dropped or damaged. Use authorized service for examination, electrical or mechanical adjustment or repair.
6. CAUTION: Equipment surfaces are HOT during use and a short time after disconnecting the power. Allow to cool before moving or servicing.
7. WARNING: DO NOT immerse in water or other liquid. DO NOT clean with water jet. SEVERE personal injury or death can result.

ELECTRICAL REQUIREMENTS

1. The electrical ratings are listed on the equipment's Data Tag located on the side of this equipment.
2. Model 6600 is rated 120 Volts, 1800 Watts, 15Amps and has a NEMA 5-15P plug and grounded cord.
3. This equipment must be properly GROUNDED.
Note: This unit is equipped with a Hi-Limit reset button (located on the rear of the unit). To reset this thermostat, unplug the unit and allow unit to cool for approximately 45 minutes. Remove cap located on the reset switch and fully press the reset button and reinstall cap.

PREPARATION

1. Remove all packing pieces and lift unit out of the box.
2. Remove any outside packaging.
3. Set unit on a flat surface. REFER to SAFETY INSTRUCTIONS No. 1 above.
4. Position unit near the power outlet. Avoid the use of extension cords. Do not run cord under carpeting or cover with runners or the like. Arrange cord where it will not be tripped over.
5. This appliance has hot and live electrical parts inside. Do not use it in areas where gasoline, paint or flammable liquids are used or stored.
6. Unit must be operated with legs installed.
7. Remove any white plastic coating that may be affixed to exterior surfaces.
8. If unit fails to work properly when first operated, call NEMCO customer service at 1-800-782-6761.

OPERATION

1. Plug the unit into the power supply.
2. Open tank cover and verify that filter inside tank is installed properly. Fill unit with approximately 3 quarts of cold tap water (Do NOT overfill the tank). Note: 6600 is designed to use cold tap water. Distilled water may be used to reduce calcium/mineral deposit build-up and reduce maintenance costs.
3. Turn on/off switches to the on position and allow the unit to preheat for approximately 30 minutes. Note: Do NOT push the operate button during warm-up.
4. Open the top cover and place the product to be steamed onto the Trivet and then close the top cover.
5. Press the OPERATE button for 1 second then release and wait 20 seconds for the steam to penetrate the product. Repeat if product requires more steam. Note: Pressing and holding the OPERATE button for longer than 1 second at a time and/or too often will flood out the generator surface and result in poor steaming.
6. Remove steamed product.
7. To disconnect appliance, turn switch to off and remove plug from outlet.

WARNING: DURING NORMAL OPERATION, THE EXTERIOR OF THE UNIT IS HOT.

CLEANING

NOTE: Proper maintenance plays an important part in the life span and functioning of the unit.

DAILY MAINTENANCE

1. Move the power switch to the OFF position. Unplug the power cord.
2. Allow the unit to cool 45 minutes.
3. Wipe down the unit using a damp cloth or sponge and hot detergent water.
4. Rinse by wiping with a clean damp cloth.
5. Wipe dry.
6. Do not immerse in water or other liquid.

MONTHLY MAINTENANCE

1. Turn the power off, unplug the power cord, and allow the unit to cool down before proceeding.
2. Perform the Daily Maintenance.
3. Remove the spray tube by lifting the loose end and pulling it out of the generator hole.
4. Slide the metal cover off of the Spray Tube, take a paper clip and poke out all of the tube's holes.
5. Gently wash the tube under running water to clear the deposits out of the loose end. Reattach the cover onto the tube. Note: Do not bend the Spray Tube. The tube is made of Teflon and any bends in the tube will result in permanent damage.
6. Use a scraper or spatula to remove excessive calcium/mineral buildup from the Generator surface.
7. Thoroughly wipe the Generator with a damp cloth to remove any loose buildup and reassemble the unit.

Note: If deposits are still excessive and/or difficult to remove, refer to Steps 1 through 6 below.

1. Pour delimer solution onto the Generator surface. Follow the delimer manufacturer's instruction for proper mixture and use.
Caution: If a chemical cleaner is used, be sure it is safe to use on cast aluminum. Observe all precautions and warnings on the product label.
2. Using a sponge or a dry towel, remove the delimer solution from the Generator surface and then rinse the surface with clean water.

Note: To ensure proper steaming characteristics, some calcium/mineral deposits must be present on the Generator surface. If, during cleaning, the surface does become free of calcium/mineral deposits, add plain tap water to the surface and allow it to boil off. If necessary, repeat this process to formulate a thin coating of calcium/mineral deposits.

Note: In soft water areas, it may be necessary to add a small amount of lime to the Generator surface to season it. This will ensure proper steaming characteristics by producing a thin coating of calcium/mineral deposits on the Generator surface.

Seasoning mixture consists of $\frac{3}{4}$ ounce baking soda, $\frac{3}{4}$ ounce lime mixed with 1 quart of water. Stir mixture and pour $\frac{1}{4}$ " deep onto the hot Generator surface. After mixture is converted to steam, the remaining loose powder can be removed.

3. Plug the power cord into the appropriate outlet.
4. Turn the power on and allow the unit to warm up for approximately 30 minutes.
5. Push and release the Operate button several times to purge and remaining delimer residue from the Generator surface.
6. Turn power off, reinstall all parts and accessories and return the unit to service.

WATER TANK FILTER MAINTENANCE

The Water Tank Filter is used to prevent particles or food products from entering and damaging the water pump. Inspect and clean this filter monthly or more regularly using the following procedure.

1. Turn the power off, unplug the power cord, and allow unit to cool down before proceeding.
2. Open the Slide Door.
3. Remove the Water Tank Filter, located inside the tank, by pulling it upwards and out of the bottom hole.
4. Clean the filter by running it under tap water. Replace the Water Tank Filter if the screen is torn or damaged.
5. Reinstall the Filter Stem into the bottom hole of the tank.
6. Fill the Water Tank and test unit.

SERVICE INSTRUCTIONS 6600

If the unit fails to operate properly, call NEMCO customer service toll free at 1-800-782-6761. .



Figure A - Steamer Components

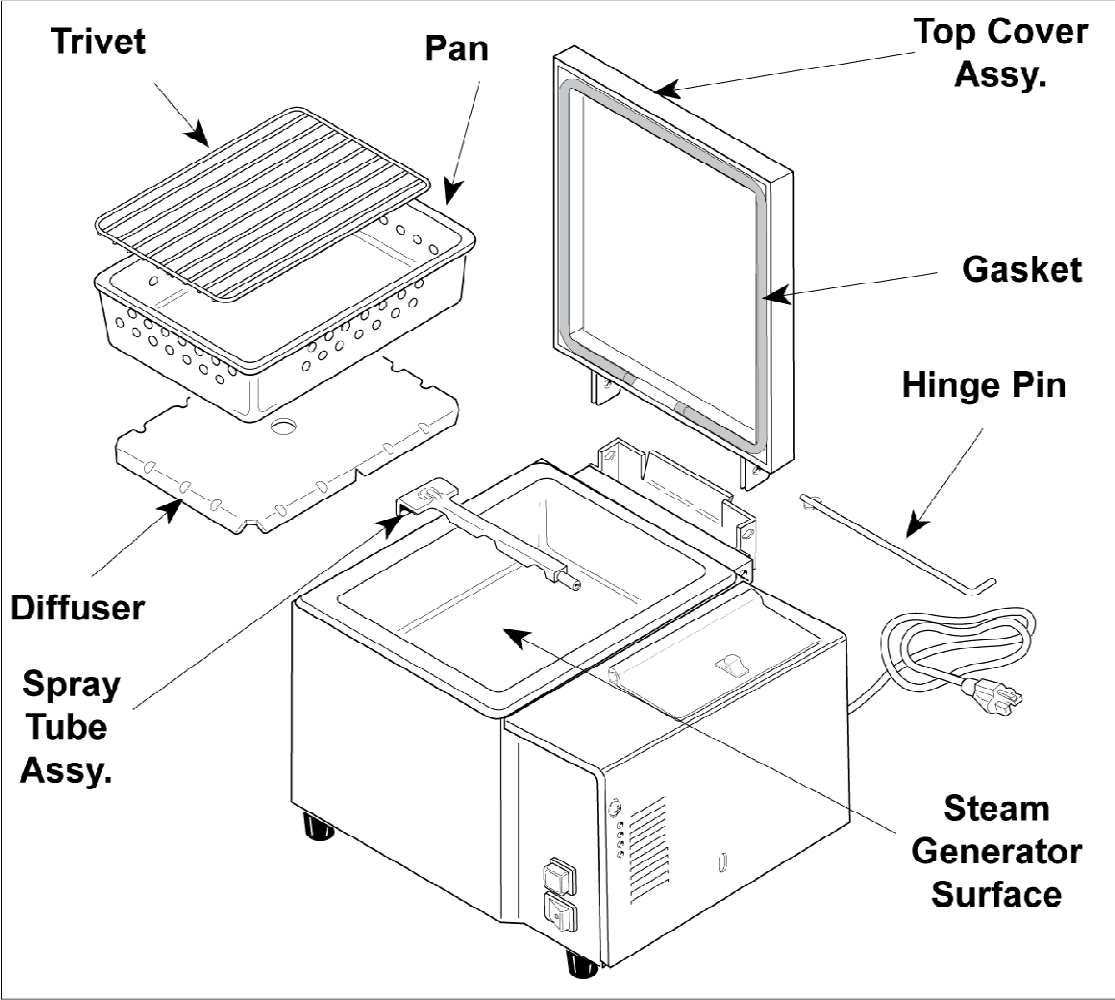
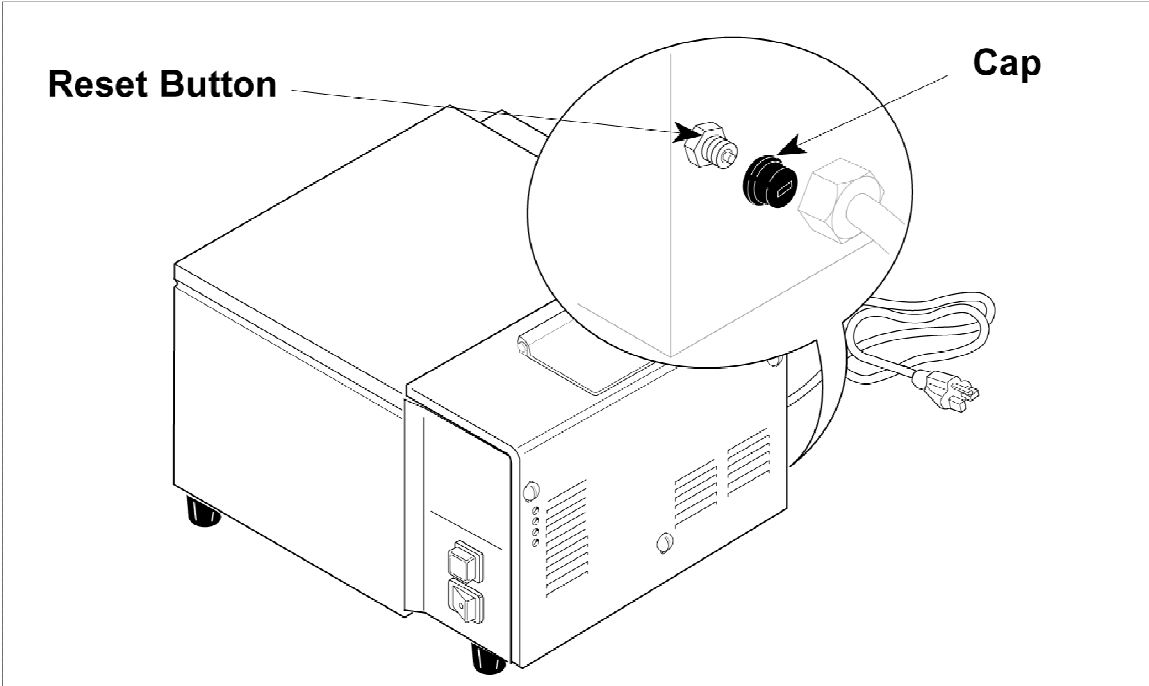
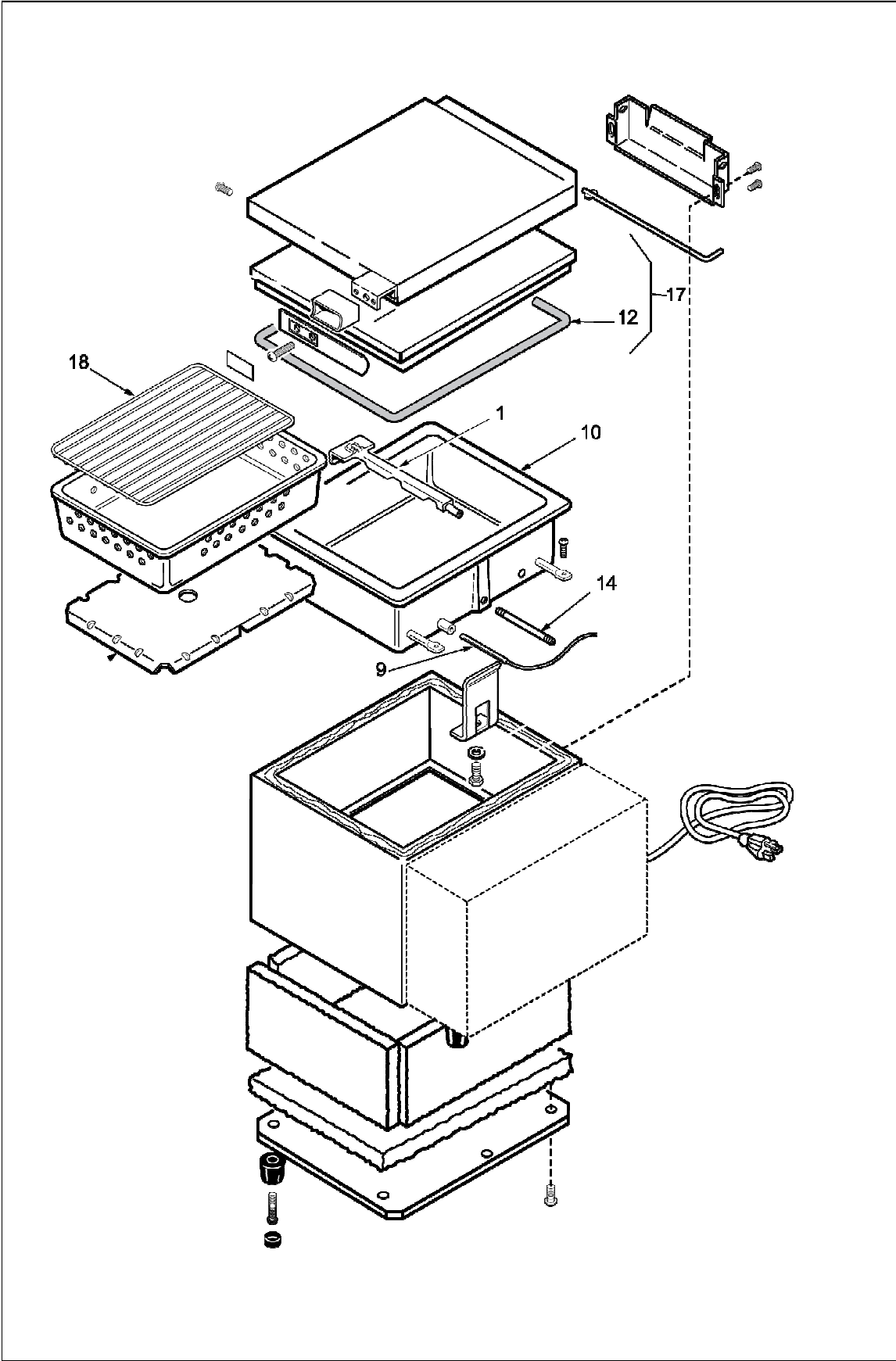

Figure B - Hi Limit Reset



Exploded View 6600



Exploded View 6600

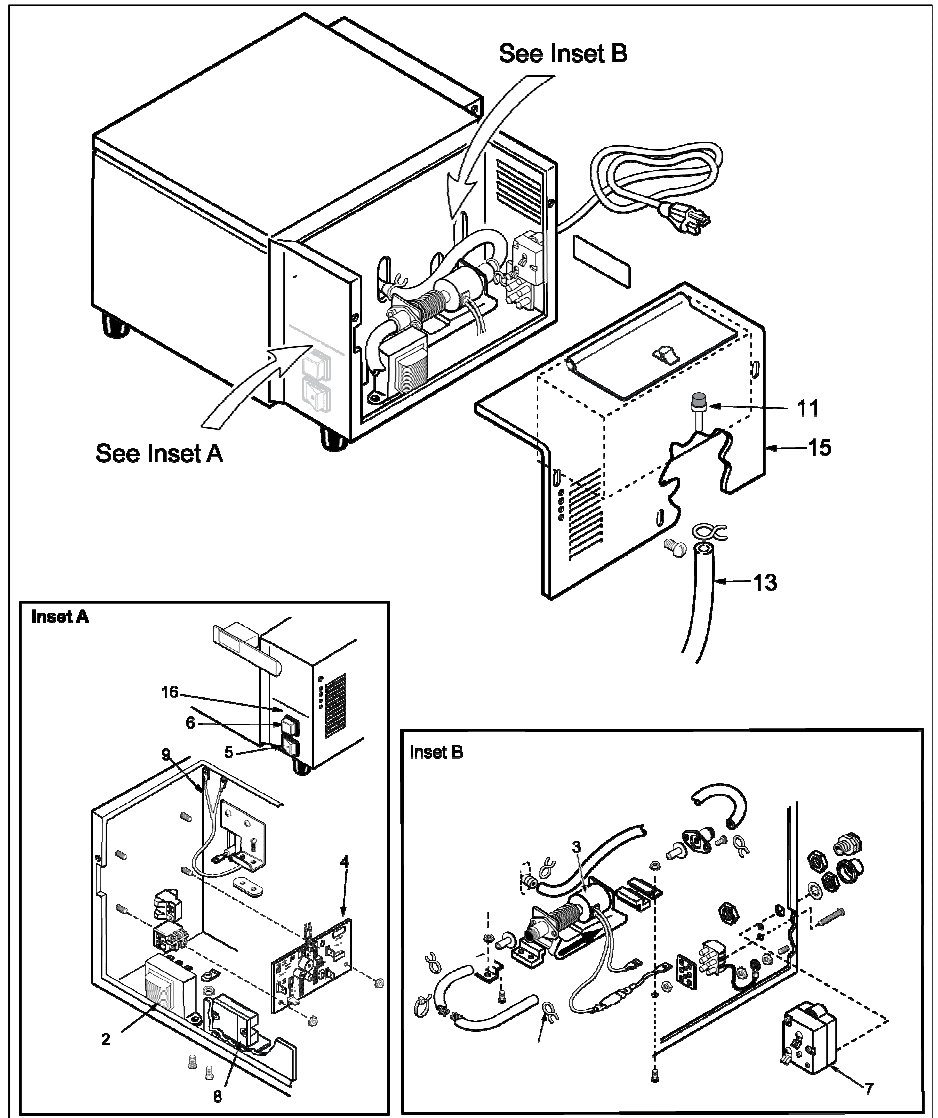

Service Parts List 6600

Item	Part No.	Description	Qty Used
1.	68782	Spray Tube Assembly	1
2.	68783	Transformer	1
3.	68784	Pump	1
4.	68785	Control Board	1
5.	68786	Rocker Switch	1
6.	68787	Momentary Switch	1
7.	68788	Hi Limit Thermostat	1
8.	68789	Solid State Relay	1
9.	68790	Thermistor	1
10.	68791	Generator	1
11.	68792	Water Tank Filter	1
12.	68793	Cover Gasket	1
13.	68794	Silicone Tube Kit	1
14.	68795	Generator Tube	1
15.	68796	Water Tank / Cover Assembly	1
16.	68797	Control Panel Label	1
17.	68798	Top Cover Assembly	1
18.	68799	Trivet	1
19.	68800	Silicone High Temperature	1