



UPRIGHT REACH-IN DUAL TEMPS

Top Mounted Condensing Unit

ES – Series

• ESRFH2 • ESRF2 • ESWRF2 • ESWQ3 • ESRF3

Cabinet Construction

Heavy duty stainless steel interior and exterior, and galvanized steel finished top, bottom and back wall of exterior. ABS evaporator drain cover. 2.5" thick high density foamed-in-place polyurethane insulation. Four 4" diameter casters (front casters with brakes). Door heater installation around inside cabinet frame to prevent moisture build-up.

Refrigeration System

- Self-contained condensing unit located at top of cabinet for high performance
- Oversized condenser and evaporator coil cools to set and maintain temperature in minimum time period
- Forced-air cooling with dual evaporator fan motors providing balanced airflow throughout cabinet to ensure faster temperature drop
- Environmentally friendly CFC free R-134A and R-404A refrigerant
- Adjustable, time initiated defrost cycle of 3 to 12 hours with 350 watt heater, both time and temperature terminated for fail-safe backup
- Automatic evaporator fan motor delay on defrost cycle
- Copper tube and aluminum fin evaporator with anti-corrosive coating
- Energy efficient condensate drain pan located at bottom of cabinet constructed of anodized aluminum
- Two pressure relief ports located at exterior back wall and top of cabinet for rapid re-entry
- Pre-wired and ready to plug, 115V/60Hz/1Ph, NEMA 5-15P

Doors

- Heavy duty stainless steel interior and exterior
- 2.5" thick high density foamed-in-place polyurethane insulation
- Rounded corners for a sleek and modern appearance
- Heavy duty adjustable torsion spring self-closing door system
- One piece snap-in magnetic door gasket for easy replacement
- Heavy duty recessed door handles for a flat surface
- Door locks
- Field reversible doors (*available from 2013 models*)

Lighting

- Safety shielded incandescent interior lighting

Shelving

- Three epoxy coated wire shelves per section
- Stainless steel pilasters and shelf clips

Temperature Control

- Factory preset temperature, 35°F for refrigerators and -4°F for freezers
- Temperature setting range from 33°F to 41°F for refrigerators and -10° F to 35° F for freezers
- Easy to read digital temperature display
- Easy to program push button temperature control
- Microchip digital monitoring system with a variety of functions to monitor and maintain optimum temperature



ESRFH2



ESRF2



ESWRF2



ESWQ3



ESRF3

<ul style="list-style-type: none"> • Project / Customer _____ • Item No. _____ • Model No. _____ 	<p>Warranty</p> <p>2 Year — Parts & Labor 5 Year — Compressor</p>	<p>Please visit our website for updated Energy Efficiency information</p> <p>201 W. Artesia Blvd, Compton, CA 90220 T. (310) 323-6586, (800) 444-6285 F. (310) 323-7524 www.EVERESTref.com</p>
---	--	--

UPRIGHT REACH-IN DUAL TEMPS

Top Mounted Condensing Unit



EVEREST
REFRIGERATION

ES – Series

• ESRFH2 • ESRF2 • ESWRF2 • ESWQ3 • ESRF3

Dimensions

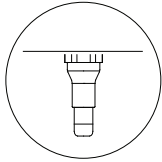

Two additional front adjustable stainless steel clad ABS legs for model ESRFH2 to prevent movement of unit when opening and closing doors

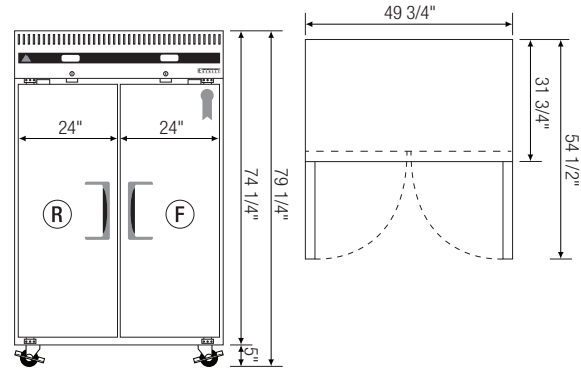

▲ ESRF2

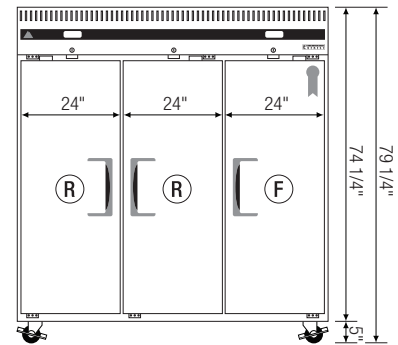
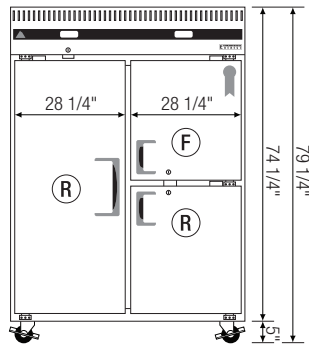
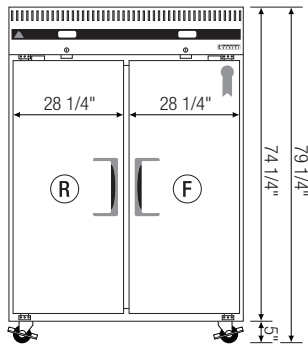
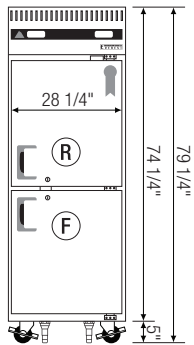
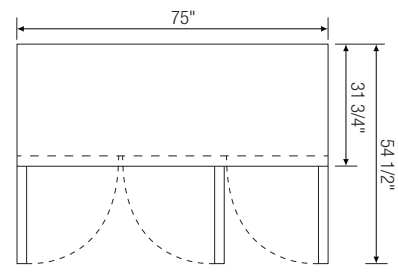
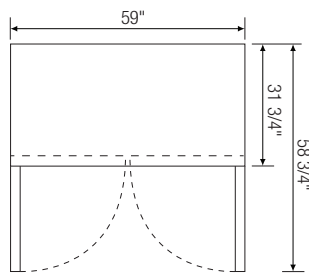
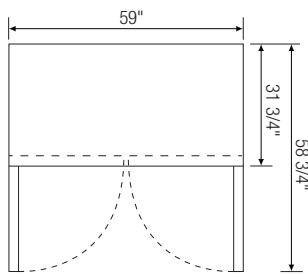
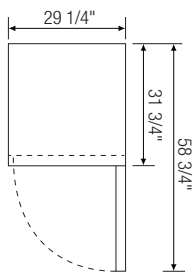

▲ ESRFH2

▲ ESWRF2

▲ ESWQ3

▲ ESRF3

Model	Ref/ Fzr/ Dual	# of Doors	Capacity (Cu.Ft.)	HP	Refrigerant	# of Shelves	Power (V-Hz-Ph)	Amps	Crated Weight (LBS)	Exterior Dimensions (Inches)			* Height does not include 5" for casters. Ref = Refrigerator Fzr = Freezer Dual = Ref & Fzr Combo H = Half Door
										L	D	H*	
ESRFH2	Dual	2(H)	11(Ref) 11(Fzr)	1/2	R-404A	2	115-60-1	7.70	315	29 1/4	31 3/4	74 1/4	
ESRF2	Dual	2	22(Ref) 22(Fzr)	1/3(Ref) 1/2(Fzr)	R-134A(Ref) R-404A(Fzr)	6	115-60-1	12.25	481	49 3/4	31 3/4	74 1/4	
ESWRF2	Dual	2	26(Ref) 26(Fzr)	1/3(Ref) 1/2(Fzr)	R-134A(Ref) R-404A(Fzr)	6	115-60-1	12.25	496	59	31 3/4	74 1/4	
ESWQ3	Dual	2(H) 1(F)	39(Ref) 13(Fzr)	1/3(Ref) 1/3(Fzr)	R-134A(Ref) R-134A(Fzr)	5	115-60-1	12.08	496	59	31 3/4	74 1/4	
ESRF3	Dual	3	46(Ref) 22(Fzr)	1/3(Ref) 1/2(Fzr)	R-134A(Ref) R-404A(Fzr)	9	115-60-1	12.36	589	75	31 3/4	74 1/4	

Specifications subject to change without notice.

www.EVERESTref.com

201 W. Artesia Blvd, Compton, CA 90220
T. (310) 323-6586, (800) 444-6285 F. (310) 323-7524