



UPRIGHT REACH-IN REFRIGERATORS

Top Mounted Condensing Unit

ES – Series

• ESR1 • ESRH2 • ESR2 • ESWR2 • ESR3

Cabinet Construction

Heavy duty stainless steel interior and exterior, and galvanized steel finished top, bottom and back wall of exterior. ABS evaporator drain cover. 2.5" thick high density foamed-in-place polyurethane insulation. Four 4" diameter casters (front casters with brakes). Door heater installation around inside cabinet frame to prevent moisture build-up.

Refrigeration System

- Self-contained condensing unit located at top of cabinet for high performance
- Oversized condenser and evaporator coil cools to set and maintain temperature in minimum time period
- Forced-air cooling with dual evaporator fan motors providing balanced airflow throughout cabinet to ensure faster temperature drop
- Environmentally friendly CFC free R-134A refrigerant
- Adjustable, time initiated defrost cycle of 3 to 12 hours with 350 watt heater, both time and temperature terminated for fail-safe backup
- Automatic evaporator fan motor delay on defrost cycle
- Copper tube and aluminum fin evaporator with anti-corrosive coating
- Energy efficient condensate drain pan located at bottom of cabinet constructed of anodized aluminum
- Two pressure relief ports located at exterior back wall and top of cabinet for rapid re-entry
- Interior airflow backward to ensure proper air circulation
- Pre-wired and ready to plug, 115V/60Hz/1Ph, NEMA 5-15P

Doors

- Heavy duty stainless steel interior and exterior
- 2.5" thick high density foamed-in-place polyurethane insulation
- Rounded corners for a sleek and modern appearance
- Heavy duty adjustable torsion spring self-closing door system
- One piece snap-in magnetic door gasket for easy replacement
- Heavy duty recessed door handles for a flat surface
- Door locks
- Field reversible doors (*available from 2013 models*)

Lighting

- Safety shielded incandescent interior lighting

Shelving

- Three epoxy coated wire shelves per section
- Stainless steel pilasters and shelf clips

Temperature Control

- Factory preset temperature, 35°F
- Temperature setting range from 33°F to 41°F
- Easy to read digital temperature display
- Easy to program push button temperature control
- Microchip digital monitoring system with a variety of functions to monitor and maintain optimum temperature



ESR1



ESRH2



ESR2



ESWR2



ESR3

• Project / Customer _____

• Item No. _____

• Model No. _____

Warranty

2 Year — Parts & Labor
5 Year — Compressor



Please visit our website for updated Energy Efficiency information

201 W. Artesia Blvd, Compton, CA 90220
T. (310) 323-6586, (800) 444-6285 F. (310) 323-7524

www.EVERESTref.com

UPRIGHT REACH-IN REFRIGERATORS

Top Mounted Condensing Unit



ES – Series

• ESR1 • ESRH2 • ESR2 • ESWR2 • ESR3

Dimensions

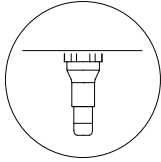

Two additional front adjustable stainless steel clad ABS legs for model ESR1 and ESRH2 to prevent movement of unit when opening and closing doors, and one additional leg for model ESR3 to support weight in the middle

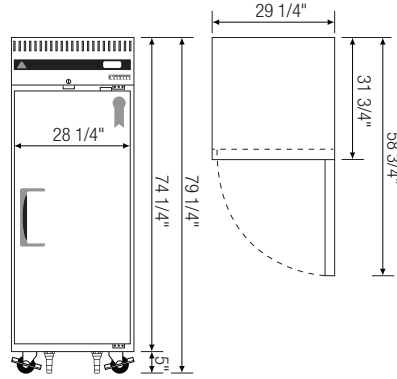

▲ ESR1

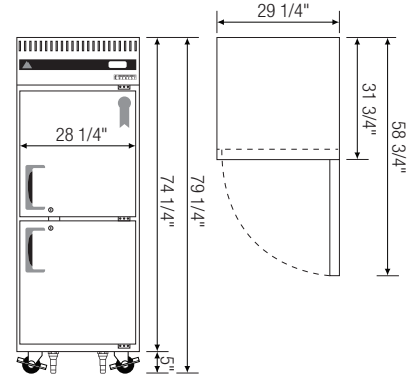

▲ ESRH2

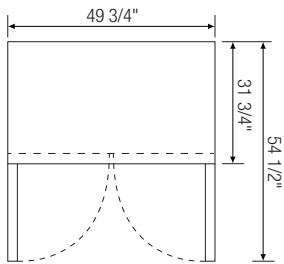

▲ ESR2

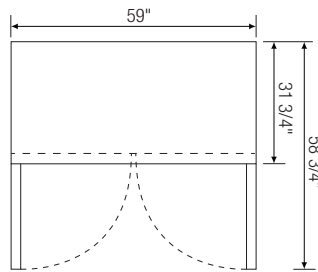

▲ ESWR2

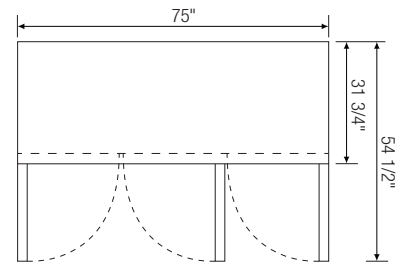

▲ ESR3

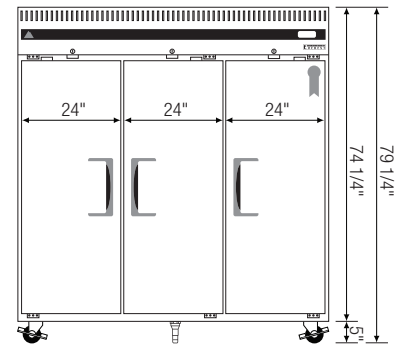
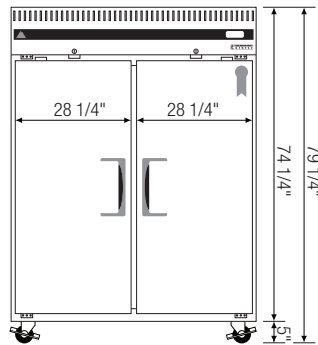
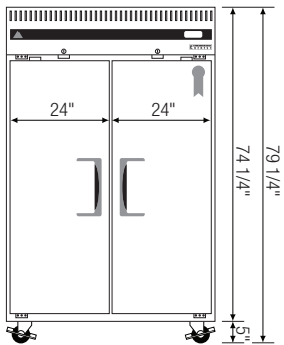

Model	Ref/ Fzr/ Dual	# of Doors	Capacity (Cu.Ft.)	HP	Refrigerant	# of Shelves	Power (V-Hz-Ph)	Amps	Crated Weight (LBS)	Exterior Dimensions (Inches)			* Height does not include 5" for caster. Ref = Refrigerator Fzr = Freezer Dual = Ref & Fzr Combo H = Half Door
										L	D	H*	
ESR1	Ref	1	23	1/3	R-134A	3	115-60-1	4.70	284	29 1/4	31 3/4	74 1/4	
ESRH2	Ref	2(H)	23	1/3	R-134A	3	115-60-1	4.70	289	29 1/4	31 3/4	74 1/4	
ESR2	Ref	2	48	1/3	R-134A	6	115-60-1	5.06	384	49 3/4	31 3/4	74 1/4	
ESWR2	Ref	2	55	1/3	R-134A	6	115-60-1	5.06	421	59	31 3/4	74 1/4	
ESR3	Ref	3	71	1/3 x 2	R-134A	9	115-60-1	9.49	595	75	31 3/4	74 1/4	

Specifications subject to change without notice.

www.EVERESTref.com

201 W. Artesia Blvd, Compton, CA 90220
T. (310) 323-6586, (800) 444-6285 F. (310) 323-7524