

Item No.

The Front Operated SDR-42, Newest In A Long Line Of Anets Dough Rollers.

This latest addition to the Anets line is a no-frills workhorse. The large capacity dough chute and heavy-duty motor can handle any type of dough. Reduced work height and simplified roller adjustments were engineered with the operator in mind. The small footprint and compact design make this ideal for any kitchen. Get the job done, safely and quickly with the NEW Anets SDR-42 dough roller.

STANDARD FEATURES

- Safety features assure operator safety: safety dough chute, safety interlock, special guarding...Meets OSHA requirements.
- Adjust dough thickness using levers secured by large ergonomic knobs.
- Hinged front door for easy access to rollers and scraper blades.
- Front door is equipped with a safety interlock that stops rollers when opened.
- Scraper blades are easy to remove for cleaning and numbered for easy replacement.
- Reduced height for more comfortable operation.
- Maintenance free drive train, sealed and self lubricating.
- All mechanical parts are located in an enclosed compartment separate from the roller area.
- ON/OFF switch has a cover for protection from flour and water.
- Extra wide dough hopper accommodates large (42 oz) dough balls. Also allows the operator to use the top set of rollers for the second pass to make a thicker dough piece.



Simplified infinite roller adjustment.



Anets SDR-42 Front Operated Two Pass Dough Roller

Model SDR-42

SPECIFICATIONS

- Model SDR-42 Front Operated Two Pass Dough Roller
- Certification UL, NSF, Meets OSHA requirements
- Electrical Requirements 115V, 10 AMP, 50/60 Hz, Single phase
- Electrical Connection 9' grounded cord and plug
- Motor 3/4 HP, 9 Amps, Self lubricating
- Dough Capacity 42 ounce dough ball
- Roller Size 3-1/2" (9cm) diameter, 20" (51 cm) wide
- Roller Quantity 3
- Roller material Chrome plated (Synthetic optional)
- Roller speed 80 feet per minute (@ 60 Hz)
- Cabinet Finish FDA approved white powder coating
- Dimensions (H x W x D) 25" X 27" X 24" (64 cm X 69 cm X 61 cm)
- Legs 4" chrome plated (adjustable)
- Shipping weight 220 Lbs.

OPTIONS AND ACCESSORIES

- Synthetic rollers
- Second pass chute extension
- Special voltages available

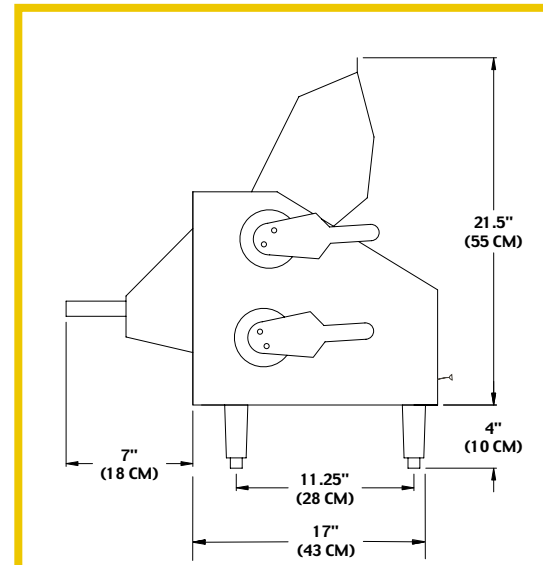

Side View

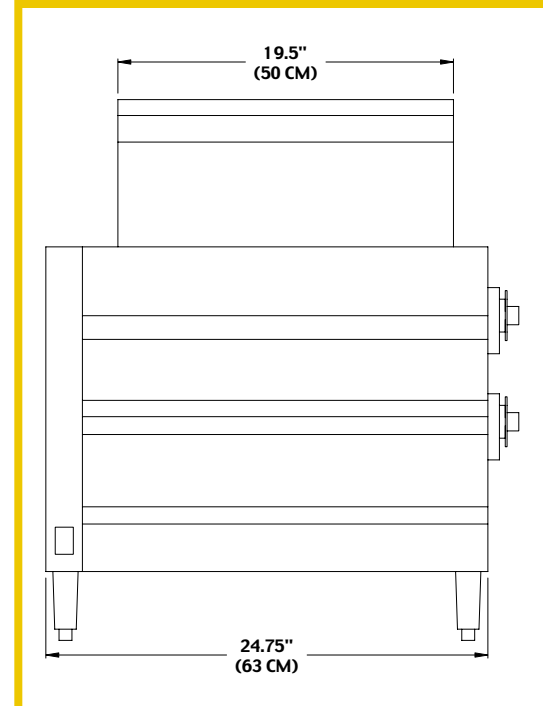

Front View

Specifications subject to change without notice.
SS# 507 Revised 10/01
Printed in the U.S.A.



Anetsberger Brothers, Inc. ■ Foodservice Equipment That Turns Food Into Gold
180 North Anets Drive ■ Northbrook, Illinois 60062
1-800-837-2638 ■ Fax 847-272-1943 ■ www.anetsberger.com