



## Slide in Electric Rangetops – Install Quick Specs CTE 48” Wide

Model	Cutout Dimensions		
	A	B*	C
CTE48P	45 3/8"	24 3/4"	48 1/8"

\*Dimension “B” will depend on your countertop design.

### Installation Type

Fig. A - Slides into cabinet/countertop opening  
Fig. B – Slides into notched cabinet/countertop

### Standard Features

- 304 Series, 1/8” thick stainless steel framed ceramic glass
- CTE48P is designed for wall, island or peninsula installations.
- Rapid response ribbon heating elements
- Multiple cooking zone layout to accommodate a variety of pan sizes and shapes
- Shallow rough-in box depth to allow for extra cabinet storage below rangetop
- Front positioned knobs to maximize cooking surface area

### Finishes

- Black textured Ceramic Glass with Stainless Steel frame

### Maximum Power Supply Required

50 Amps @ 208/240 V AC, 3-wire, 60 Hz, single phase  
3’ flexible conduit (located in the right rear of the cooktop) comes with the unit.

### Cooktop Carton Weight:

CTE48P = 100 lbs.

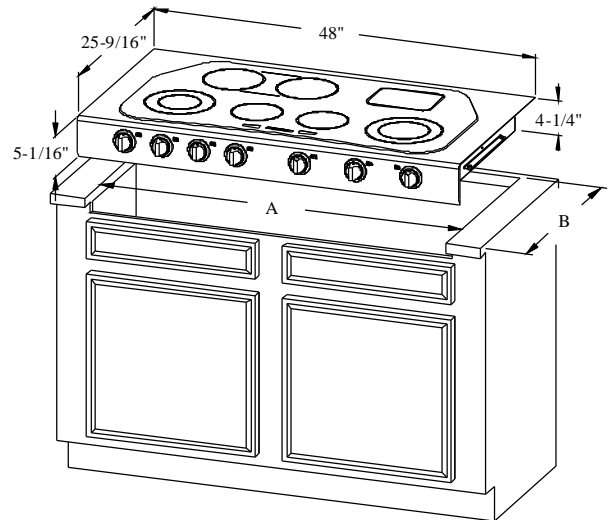

**Fig. A – CTE48P Installed without End Caps**

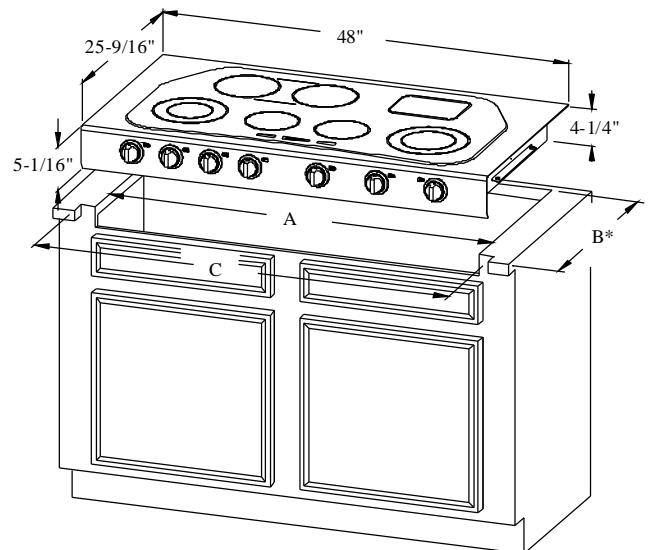

**Fig. B – CTE48P Installed with End Caps**

