

# advantage

## VITA-PREP® 3

### The professional chef's power tool

From aromatic, flavorful salsa to dense, delicious pesto, the Vita-Prep 3 is the only tool capable of blending it all. With its powerful motor and large cooling fan, chefs and culinary schools around the world trust no other blender! The Vita-Prep 3 is all the power your kitchen needs.

**Advantage: Vita-Mix®.**



**Vita-Mix**  
FOODSERVICE

# VITA-PREP® 3

## FEATURES

- ≈ 3 peak HP motor
- New ventilation to improve air flow
- Variable speed control
- Patented 64 oz. / 2.0 Ltr. polycarbonate container
- Patented accelerator tool
- Removable lid plug

## BENEFITS

- Increased power handles the toughest ingredients
- Eliminate overheating when blending extra thick ingredients
- Puree, grind, blend and chop at exactly the right speed
- Create a vortex – forcing ingredients up from the blades and back down the center into the blades again – for perfectly blended results
- Easily process ingredients that would bring other blenders to a halt
- Add ingredients while blending

**VITA-PREP 3** – with 64 oz. / 2.0 Ltr. Standard polycarbonate container.

Motor: ≈ 3 peak HP motor

Pack: 1 per standard pack

Weight: 13 lbs. / 5.9 kg

Case Dimensions: 13.1 in. / 33.3 cm High  
11.9 in. / 30.2 cm Wide  
16.9 in. / 42.9 cm Deep

## WARRANTY AND SERVICE CONTRACT

In the United States and Canada, the Vita-Mix Vita-Prep 3 is backed by a three-year warranty against defects in parts and workmanship and includes a one-year service contract. Other warranties apply outside the United States and Canada. Contact your local Vita-Mix Distributor for details or telephone +1.440.782.2450 for a distributor near you.

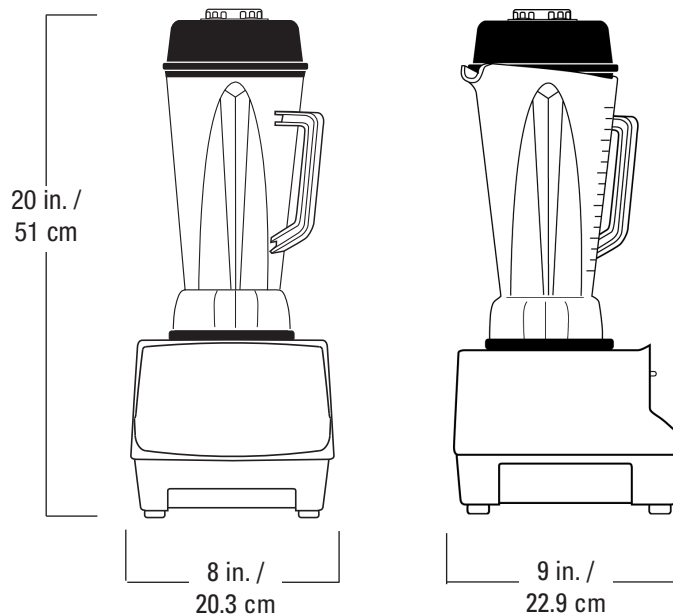

Where applicable

For more information, contact your local foodservice dealer/distributor.



## Item # Description

- 1005 Vita-Prep 3, 120V, 50/60 Hz, 12.5 Amps
- 10087 Vita-Prep 3, 100V, 50/60 Hz, 975 Watts
- 10088 Vita-Prep 3, 120V EMC, 50/60 Hz, 12.5 Amps
- 10089 Vita-Prep 3, 220-240V, 50 Hz, 1100-1200 Watts
- 10090 Vita-Prep 3, 220-240V, 60 Hz, 1100-1200 Watts

[www.vitamix.com/foodservice/vitaprep](http://www.vitamix.com/foodservice/vitaprep)

**800-4DRINK4**



FOODSERVICE

For a Dealer near you, contact Vita-Mix:  
US, Canada and Latin America: PHONE: 440-235-0214;  
FAX: 440-235-9670; EMAIL: [foodservice@vitamix.com](mailto:foodservice@vitamix.com)  
For a Distributor in all other countries: TEL: +1.440.782.2450;  
FAX: +1.440.782.2220; EMAIL: [international@vitamix.com](mailto:international@vitamix.com)