

**REFRIGERATOR MANUFACTURER**  
**Turbo air**  
 more durable, efficient, beautiful

4184 Conant st.  
 Long Beach, CA 90808  
 Tel. 310-900-1000  
 Fax. 310-900-1077  
[www.turboairinc.com](http://www.turboairinc.com)

Project :	
Model # :	
Item # :	Qty :
Available W/H :	
Approval :	

## Glass Door Merchandiser

Glass Door Merchandisers  
 Refrigerators

**Model : TGM-22RV  
 TGM-22RVB**

### FEATURES / BENEFITS

- **ENERGY CONSERVING FAN CONTROL**  
 Utilizing algorithmic air circulation for optimal temperature levels, our innovative fan control system conserves energy by at least 15% and increases compressor life by up to 30%.
- **HOT GAS CONDENSATE SYSTEM**  
 Through Turbo Air's creative innovation, the condensate system surfaces have been specially treated to resist corrosion. This not only increases efficiency without the risk of refrigerant leakage from corrosion, but also prevents the overflow of condensate water.
- **EFFICIENT REFRIGERATION SYSTEM**  
 Turbo Air's glass door refrigerators are designed with oversized and balanced (CFC Free R-134A) refrigeration systems. These include efficient evaporators and condensers for faster cooling and greater efficiency.
- **TASTEFUL AND MODERN APPEARANCE**  
 The design of our products is one of our top priorities. Whether you have a restaurant, bar, convenience store or gas station, Turbo Air refrigerators will compliment the appearance of your operation.
- **MAGNETIC DOOR GASKETS**  
 Magnetic door gaskets are of one piece construction, removable without tools for ease of cleaning and replacement.
- **DOUBLE PANE GLASS DOORS WITH HEAT REFLECTING FILM**  
 Equipped with unique double pane glass doors with a layer of patented, transparent thermal insulating film applied between the two glass layers. Lightweight door construction reduces door maintenance and bushing wear, and facilitates smooth door opening.
- **ADJUSTABLE, HEAVY DUTY, PE (POLYETHYLENE) COATED WIRE SHELVES**
- **HIGH-DENSITY POLYURETHANE INSULATION**  
 The entire cabinet structure and solid doors are foamed-in-place using high density, CFC free polyurethane insulation.
- **ERGONOMICALLY DESIGNED DOORS**  
 Customers' fatigue fades away with easy grip handles and doors that open effortlessly. These features along with self-closing doors make this the ultimate choice in customer convenience.
- **BOTTOM MOUNT COMPRESSOR UNITS**  
 Turbo Air's bottom mount compressor allows easier access for service and extra storage space above. In addition, the lower area provides a cooler and less greasy operating environment which results in reduced compressor running time.
- **REFRIGERATOR HOLDS 33°F ~ 38°F FOR THE BEST IN BEVERAGE PRESERVATION**



\*Actual shelf organizer may differ in appearance with above picture.



Model	Swing Door	CU./FT.	#of Shelves	HP	AMPS	Crated Weight (lbs.)	L x D* x H (inches)
<b>TGM-22RV(B)</b>	<b>1</b>	<b>22</b>	<b>4</b>	<b>1/4</b>	<b>7.6</b>	<b>243</b>	<b>283/4 x 275/8 x 797/8</b>

## Model : TGM-22RV(B)

ELECTRICAL DATA	
Voltage	115/60/1
Plug Type	Ⓜ NEMA-5-15P
Full Load Amperes	7.6
Compressor HP	1/4
Cord Length ft.	6
Refrigerant	R-134A
DIMENSIONAL DATA	
# of Doors	1
Net Capacity cu. ft.	22
Ext. Length Overall in.	28 <sup>3</sup> / <sub>4</sub> (732mm)
Ext. Depth Overall in.*	27 <sup>5</sup> / <sub>8</sub> (702mm)
Ext. Height Overall in.	79 <sup>7</sup> / <sub>8</sub> (2028mm)
Int. Length Overall in.	24 <sup>1</sup> / <sub>8</sub> (613mm)
Int. Depth Overall in.	23 <sup>5</sup> / <sub>8</sub> (600mm)
Int. Height Overall in.	62 <sup>1</sup> / <sub>8</sub> (1580mm)
Gross Weight lbs.	243
Net Weight lbs.	225
# of Shelves	4
Shelf Size (LxD) in.	25 <sup>1</sup> / <sub>2</sub> x 19 <sup>3</sup> / <sub>8</sub>
Bottle Capacity	280 (full)

Design and specifications subject to change without notice.  
Actual shipping weight may differ due to extra packing materials for product protection.  
\* Depth does not include 1-3/8" for door handle.

- **WARRANTY : 2 Year Parts and Labor Warranty  
Additional 3 Year Warranty on Compressor**
- WHITE COLOR CABINET & BLACK COLOR FRAME ON DOOR
- WHITE AND BLACK COLOR CABINET AVAILABLE
- DOUBLE PANE GLASS DOOR WITH THERMAL FILM
- CUSTOMIZED GRAPHICS & COLORS AVAILABLE IN QUANTITY
- 2" PLATE MOUNT CASTERS (OPTIONAL)

## PLAN VIEW

(unit : inch)

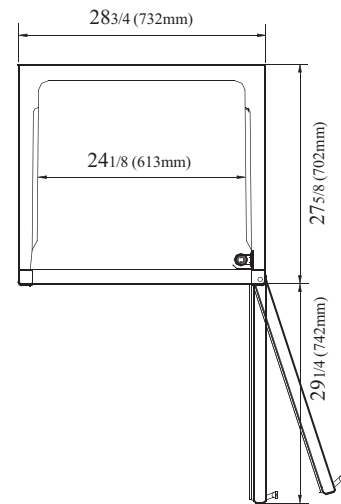

PLAN VIEW

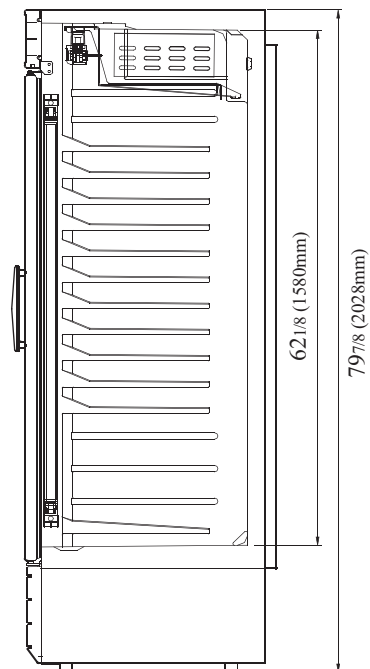

SIDE VIEW

Ver.201310



ENERGY STAR®  
Qualified

- Turbo Air : 800-627-0032
- GK : 800-500-3519
- Warranty : 800-381-7770
- AC : 888-900-1002