

HIGH QUALITY MEETS

# LOW COST

- Automatic defrost with forced air circulation
- Heavy gauge, hand dipped wire shelves
- Toughest, longest lasting door in the industry
- No plumbing or floor drains required



Model SKUCF7F

**SILVER KING**<sup>®</sup>  
WE'VE GOT REFRIGERATION DOWN COLD.<sup>™</sup>

# UNDERCOUNTER FREEZER SPECIFICATIONS

|                      |                      |   |
|----------------------|----------------------|---|
| <b>MODEL SKUCF7F</b> | <b>EXTERIOR</b>      | Stainless steel, Galvanized back.   |
|                      | <b>INTERIOR</b>      | Corrosion resistant material with coved corners throughout for easy cleaning and sanitation.  |
|                      | <b>INSULATION</b>    | Environmentally friendly foamed-in-place polyurethane insulation for maximum strength and durability.   |
|                      | <b>DOOR</b>          | Polyurethane insulation, heavy-duty extruded aluminum frame, stainless steel exterior door panel and extra heavy duty magnetic "Thermo Rubber" door gasket combine to make the toughest, longest lasting door in the industry. Door is easily reversible in the field.  |
|                      | <b>REFRIGERATION</b> | CFC-free refrigerant. Hermetically sealed, high efficiency, self contained system features automatic defrost and forced air circulation. Evaporator coil positioned for uniform air distribution and optimum cooling. Adjustable temperature control and built-in temperature indicator standard. Automatic condensate evaporator eliminates need for plumbing or floor drains. |
|                      | <b>ELECTRICAL</b>    | Standard as 115 volt, 60Hz, single phase operation with 8 foot, 3 wire power cord with NEMA 5-15P plug. Available in 230 volt, 50 Hz, single phase.   |
|                      | <b>LISTINGS</b>      | cULus (U.S. and Canada), NSF International.   |
|                      | <b>WARRANTY</b>      | One year parts and labor warranty on cabinet and refrigeration system. Five year warranty on compressor.  |
|                      | <b>ACCESSORIES</b>   | Stacking Kit, Mobility Kit.   |

| MODEL   | LENGTH | DEPTH   | HEIGHT  | STORAGE CAPACITY | SHELVES | SHELF AREA  | COMPRESSOR | AMPS | WEIGHT  |
|---------|--------|---------|---------|------------------|---------|-------------|------------|------|---------|
| SKUCF7F | 27"    | 28 7/8" | 32 1/4" | 6.5 cu. ft.      | 2       | 8.1 sq. ft. | 1/3 hp     | 7.0  | 170 lbs |



Specifications subject to change without notice.

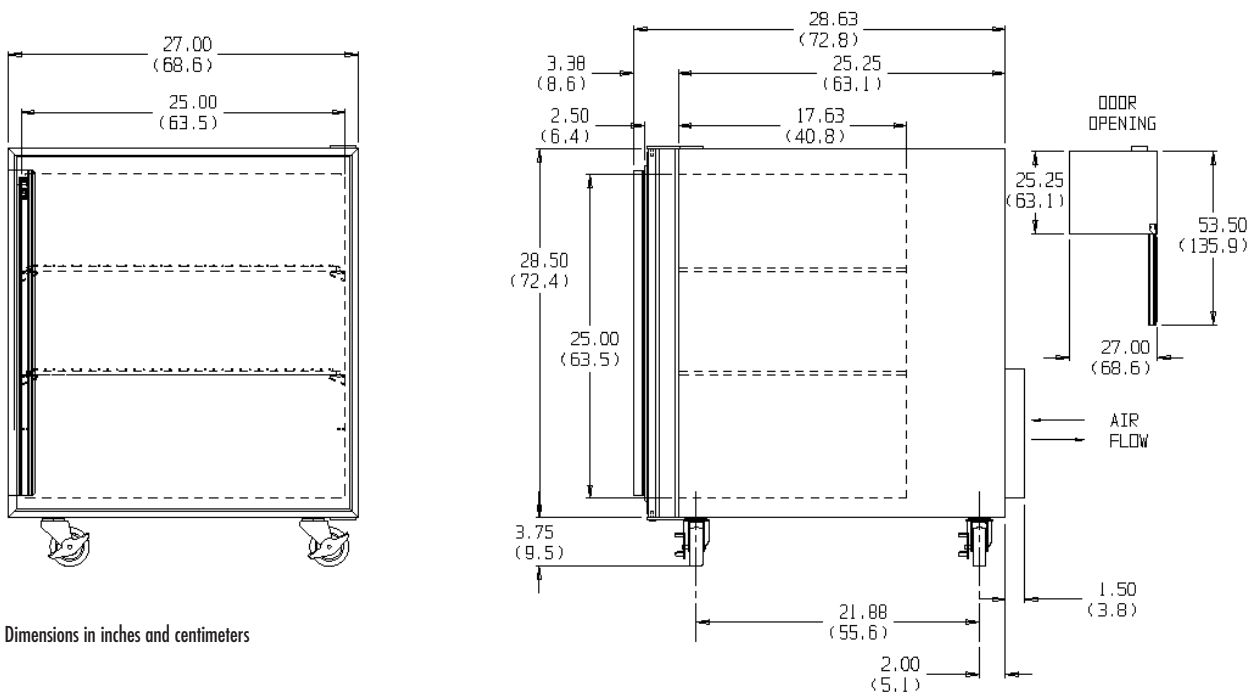

1600 Xenium Lane North  
 Minneapolis, MN 55441-3787  
 Phone (763) 923-2441  
 Fax (763) 553-1209  
 www.silverking.com

#FNSKUCF7F04  
 © Silver King 2009  
 Printed in U.S.A.