

Commercial All Metal Vegetable Processor



Shown with
optional R198
Food Tray
Cart

Optional
Bulk Feed
Assembly has
french fry
capability.

- Four different interchangeable heads available which permit machine to adapt to a wide variety of vegetable processing functions on a continuous feed basis.
- New heavy-duty 3-phase, 2-speed, 4HP motor; 425 RPM on low speed, 850 RPM on high speed, magnetic safety switch.
- Control panel with push-type "high & low" buttons and "stop" button.
- Compact design, four legs and special handle facilitates moving.
- Optional stainless steel cart with castors holds full size food box (R198) to aid in handling large volume processing.
- Stainless steel motor base.
- Packed with 2 processing discs (C446SA & C450GPA) as standard.
- Unit is water resistant, easy to clean and designed to conform to strict sanitation standards.
- 1 year warranty on parts and labor.

High Volume Vegetable Prep. Up to 1,200 lbs. per hour

For high volume processing for a wide range of sizes and shapes of vegetables and fruits. Magnetic safety switch. Accommodates 39 different processing discs. Comes with large lead assembly and one slicing and one grating disc.



Robot Coupe U.S.A., Inc.

P.O. Box 16625

Jackson, MS 39236-6625

1-800-824-1646 • (601) 898-8411

FAX: (601) 898-9134

www.robotcoupeusa.com • e-mail: info@robotcoupeusa.com

SPECIFICATIONS ON REVERSE SIDE

Specifications

STANDARD PACK: Motor base unit with large lead assembly and two discs, one 1/8" (3mm) slicing disc and one 1/8" (3mm) medium grating disc.

ELECTRICAL REQUIREMENTS: 4 H.P., 208/240V, 60Hz, Two-Speed (425/850 RPM), 5.3/5.8 Amps, Three Phase. Contact your electrician for local code requirements. NEMA L15-20 Electrical Plug.

SWITCHING: Control panel with high and low buttons, also a stop button.

MOTOR: Heavy duty, 2-speed, 4 HP, 425 RPM on low speed, 850 RPM on high speed.

WEIGHT: 150 lbs. approximate shipping wt.

PROCESSING DISCS		
* For Series D machines only		
Slicing Discs C444SA 1/32" (1mm) C445SA 5/64" (2mm) C446SA 1/8" (3mm) C477SA 5/32" (4mm) 28128* 3/16" (5mm) 28129* 5/16" (8mm) 28130* 3/8" (10mm) 28131* 9/16" (14mm) C422SA 3/4" (19mm) 28132* 25/32" (20mm) 28133* 1" (25mm)	Grating Discs C494GPA 1/16" (1.5mm) C451GPA 5/64" (2mm) C450GPA 1/8" (3mm) C475GPA 5/32" (4mm) C453GPA 3/16" (5mm) C478GPA 9/32" (7mm) C433GPA 11/32" (9mm) C495GPA Fine Pulping C452GPA Hard Cheese Grate	Julienne Discs C460JA 5/64" x 5/64" (2mm x 2mm) C483JA 5/64" x 5/32" (2mm x 4mm) C484JA 5/64" x 1/4" (2mm x 6mm) C486JA 5/64" x 5/16" (2mm x 8mm) C462JA 5/32" x 5/32" (4mm x 4mm) C438JA 1/4" x 1/4" (6mm x 6mm) C466JA 5/16" x 5/16" (8mm x 8mm)
Ripple Cut Slicers C445W 5/64" (2mm) C446W 1/8" (3mm) C464W 3/16" (5mm)	French Fry Kits 28134* 5/16" (8mm) 28135* 3/8" (10mm)	Dicing Kits 28110 3/16" x 3/16" (5mm x 5mm) 28111 5/16" x 5/16" (8mm x 8mm) 28112 3/8" x 3/8" (10mm x 10mm) 28113 9/16" x 9/16" (14mm x 14mm) 28114 25/32" x 25/32" (20mm x 20mm) 28115 1" x 1" (25mm x 25mm)
Romaine Lettuce Kit 28133/104031 2"		

OPTIONAL EQUIPMENT: 37 additional processing discs. Single, free-standing 3-position disc rack or wall-mounted disc rack. R198 food box cart with container. 3 lead assemblies – Bulk feed assembly, Angle feed lead, small lead assembly.

STANDARDS: ETL electrical & sanitation, cETL (Canada)

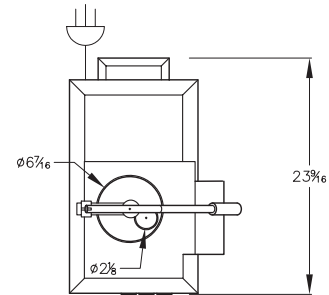
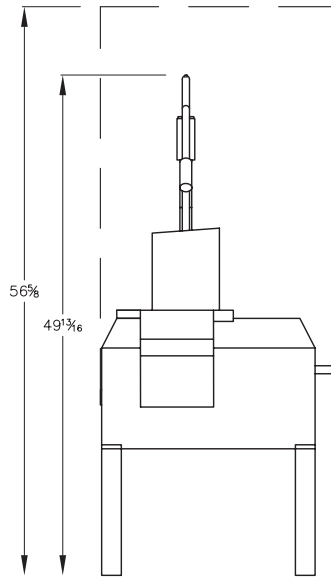
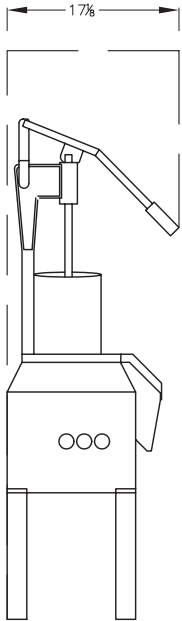

Robot Coupe U.S.A., Inc.

P.O. Box 16625

Jackson, MS 39236-6625

1-800-824-1646

(601) 898-8411

FAX: (601) 898-9134

www.robotcoupeusa.com

e-mail: info@robotcoupeusa.com

Distributed by: