

## **Light-Duty Vegetable Prep and Vertical Cutter-Mixer**



**Prepare 400 servings  
in 3 hours.**

Extended shaft accommodates 21 different processing plates to slice, shred, grate and julienne.

Bowl and stainless steel cutter blade designed for mixing, chopping, pureeing, blending and kneading.

- Two machines in one.
- Cover and bowl easily removed for cleaning.
- Two deep feed openings.
- Patented “Sabatier” stainless steel cutting blade.
- Stock-pot shaped 2 1/2 qt. cutter bowl with see-thru lid.
- Optional clear cutter bowl.
- Direct drive, fan cooled 5/16 HP motor.
- Packed with two cutting plates as standard.
- Attractive, clean, compact design.
- 1 year parts and labor warranty.

**Robot Coupe U.S.A., Inc.**

P.O. Box 16625

Jackson, MS 39236-6625

1-800-824-1646 • (601) 898-8411

FAX: (601) 898-9134

www.robotcoupeusa.com • e-mail: robocoup@misnet.com

**SPECIFICATIONS ON REVERSE SIDE**



## Specifications

**STANDARD PACK:** Motor base unit, cutter bowl with stainless steel "Sabatier" blade, cover with feed lead, one medium 5/64" grating plate and one 5/32" slicing plate.

**SWITCHING:** Push "ON-OFF" safety type will not operate unless cover and bowl are in proper position.

**BOWL CAPACITY:** 2 1/2 qts.

**ELECTRICAL:** 120V, 60Hz, 7 Amps. Contact your local electrician for local code requirements.

**MOTOR:** 5/16 HP, fan cooled, single phase, 1725 RPM.

**WEIGHT:** 22 lbs. net, 25 lbs. approximate shipping weight.

**OPTIONAL EQUIPMENT:** 19 additional processing plates. Free-standing plate rack holds 9 plates. Stainless Steel Bowl.

**STANDARDS:** ETL-Sanitation, ETL-Electrical.

## Processing plates:

### Slicing Plates

**R210** - 5/64" (2mm)

**R211** - 5/32" (4mm)

**R270** - 1/4" (6mm)

**R291** - 1/32" (1mm)

**R292** - 1/8" (3mm)

**R293** - 3/16" (5mm)

### Grating Plates

**R271** - 1/64" (0.5mm) Hard Cheese

**R208** - 1/16" (1.5mm) Fine

**R209** - 5/64" (2mm) Medium

**R281** - 1/8" (3mm) Medium Coarse

**R280** - 1/4" (6.5mm) Coarse

**R215** - 3/8" (9mm) Extra Course

### Pulping Plates

**R294** - 1/64" (.7mm) Pulping

**R295** - 1/32" (1mm) Pulping

### Waved Slicing Plate

**R212** - 1/16" (2mm)

### Julienne Plates

**R213** - 1/4" (6x6mm)

**R214** - 5/64" (2mm)

**R288** - 5/32" (4mm)

**R296** - 5/64" X 5/32" (2x4mm)

**R297** - 5/64" X 1/4" (2x6mm)

**R298** - 5/16" X 5/16" (8x8mm)

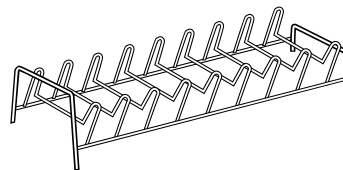
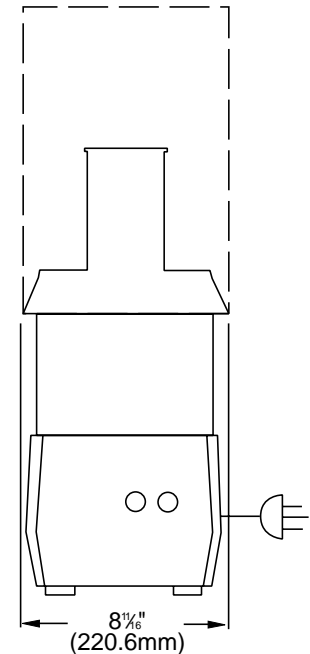
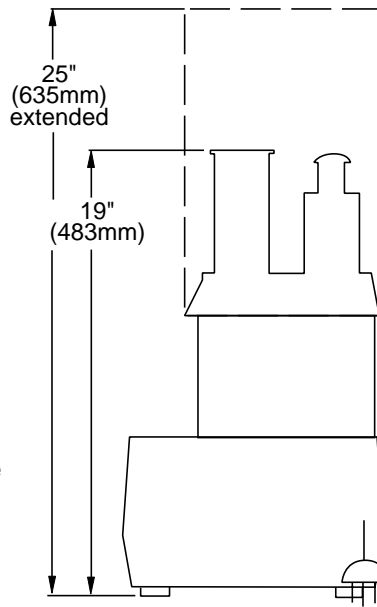
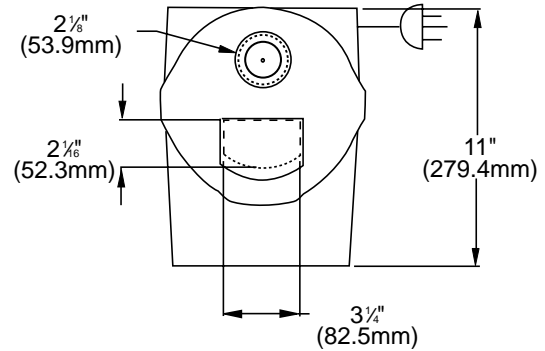

**R255**  
Plate Rack

**Robot Coupe U.S.A., Inc.**

P.O. Box 16625

Jackson, MS 39236-6625

1-800-824-1646

(601) 898-8411

FAX: (601) 898-9134

www.robotcoupeusa.com

e-mail: robocoup@misnet.com

## Distributed by: