



MONTAGUE TECHNOSTAR

Medium-Duty

36" Restaurant Ranges

Item No. _____

Project _____

Quantity _____



Model VT26-6

SHORT/BID SPECIFICATION

Range shall be a Montague *Technostar* Model: a 36" wide, gas heated medium-duty restaurant range mounted on [Specify Base Prefix]:

- T26-Series:** a 26-5/8" wide front-vented 35,000 BTU/hr conventional oven with heavy-duty door, porcelainized steel interior, four-position rack guides with one wire rack standard with high-shelf/flue riser
 - VT26-Series:** a 26-5/8" wide front-vented 40,000 BTU/hr convection oven with heavy-duty door, porcelainized steel interior, five-position rack guides with three wire racks standard and high-shelf/flue riser
 - TC-Series:** a stainless steel counter top base with 4" flue riser and 4" legs
- [Specify Top Suffix]:
- [-6] with six 12" x 12.5" cast iron open top grates, over six 30,000 BTU/hr cast iron burners, with individual burner controls and automatic standing pilots;
 - [-4-1FT] with four 12" x 12.5" cast iron open top grates, over four 30,000 BTU/hr cast iron burners and one 12" wide 1/2" thick frytop with one 20,000 BTU/hr burner, with individual burner controls and automatic standing pilots;
 - [-2-2FT] with two 12" x 12.5" cast iron open top grate, over two 30,000 BTU/hr cast iron burners and one 24" wide 1/2" thick hot top with two 20,000 BTU/hr burners, with individual burner controls and automatic standing pilots;
 - [-3FT] with 36" wide 3/4" thick frytop with three 20,000 BTU/hr burners, with individual burner controls and automatic standing pilots;

...plus stainless steel front and sides and 4-5/8" deep front rail standard; plus all the features listed and options/accessories checked:

TECHNOSTAR TOP FEATURES:

Open Burner Sections are 12" wide x 27" deep with:

- Two-piece cast iron, surface-ground top grates over
- Two 30,000 BTU/hr cast iron star burners
- Automatic, standing pilots
- Drip pans positioned under burners

Frytops Sections (Griddle) are 12" wide [-1FT]; 24" wide [-2FT]; or 36" wide [-3FT] and 24" deep, with:

- 1/2" thick precision-ground steel cook surface
- 2" high backsplash and tapered side-splashes
- 2-5/8" wide front grease gutter
- Built-in grease drawer
- One 20,000 BTU/hr gas burner with standing pilots & gas control valve, per 12" section
- Adjusting bolts for changing top plate forward pitch

STANDARD OVEN FEATURES [T26]:

- 26-5/8" and 26" deep x 14-1/4" high cooking compartment
- Front-venting oven design for more even cooking
- Heavy-duty counterweighted oven door — no springs
- Four-position adjustable nickel-plated rack supports, with one rack standard
- Oven bottom and door porcelain lined for long life & easy cleaning
- Side & back liners are stainless steel
- 250-to-500°F (260°C) thermostat mounted left of oven door
- 35,000 cast iron burner with automatic ignition safety pilot

CONVECTION OVEN FEATURES [VT26]:

- 26-5/8" wide x 22-1/4" deep x 14-1/8" high cooking compartment
- Single speed motor with fan
- Front-venting oven design for more even cooking
- Heavy-duty counterweighted oven door — no springs
- Five position adjustable nickel-plated rack supports, with three racks standard
- Oven bottom and door porcelain lined for long life & easy cleaning
- Side & Back liners are stainless steel
- 250-to-500°F (260°C) thermostat mounted left of oven door
- 40,000 BTU/hr cast iron burner with automatic ignition safety pilot
- 6' (1829 mm) cord with 3-prong plug (grounding MEMA)

STANDARD CONSTRUCTION FEATURES:

- Satin finish stainless steel front and sides with 4-5/8" deep front rail
- 21-1/2" high-shelf is standard on T26- & VT26- Models
- Stainless steel 4" rear flue riser standard on TC- Models
- 6" adjustable legs standard
- 4" legs standard on TC- Models
- 1" gas pressure regulator is provided as standard [All models]
- 3/4" rear gas connection

AGENCY APPROVALS

- NSF Listed
- CSA Design Certified to ANSI Z83.11 • CSA 1.8
- CE Approved • EN 203-1



MDR-2 [Rev. 08/11]

THE MONTAGUE COMPANY • 1830 Stearman Avenue, Hayward, CA 94545 • 800 345-1830 • Fax: 510 785-3342 • montaguecompany.com

Medium-Duty 36" (914mm) Restaurant Ranges

Dimensions in brackets are millimeters

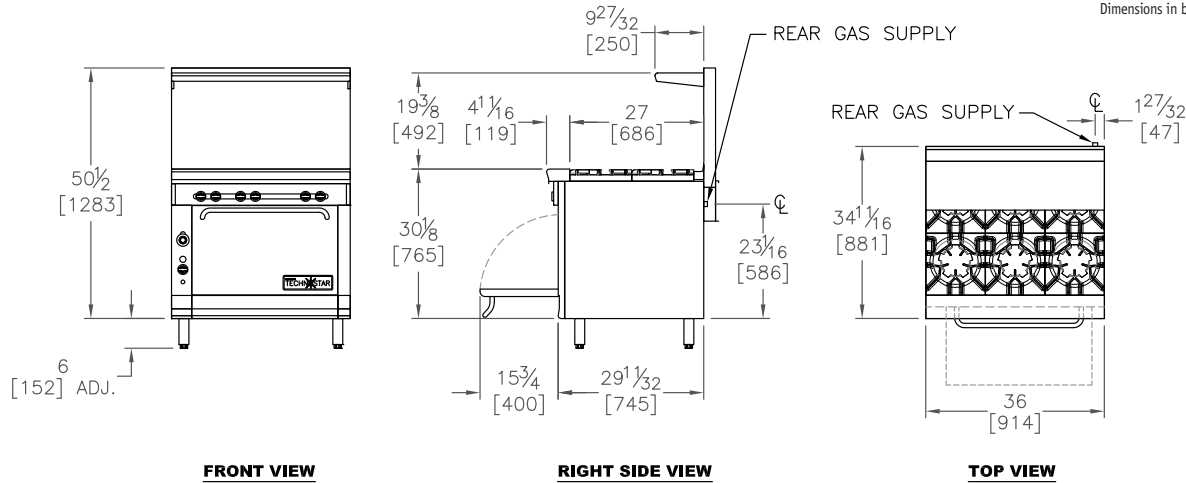

OPTIONS GUIDE:

For Frytop (Griddle) Sections:

- 3/4" (19mm) thick plate
- 1" (25mm) thick plate - Not available on -1FT
- Thermostat control(s) [Add to Suffix: -FTT]
- 4" (102mm) removable side splash:
 - left right
- Substitute Work Top for Open Burners
 Use Suffix: -__WS [Specify number: 1 - 3]

Finish:

- Stainless steel back panel

Controls:

- Flame failure rangetop safety valves

Flue Risers [In Lieu of High Shelf]:

- 4" (102mm) high riser:
- 21-1/2" (546mm) high riser

For Ovens:

- Extra oven racks: ____ea.
- 3/4 HP fan motor [VT26 Models]
- 208/240-volt power connection [VT260 Models]

General:

- Casters — set of four 5" (127mm) casters
- Curb Mounting — Non combustible floors only
- Flex Connector Kit [3/4" (19mm)]**
 - 3' (910mm) 4' (1220mm)

International Approvals:

- CE - Conformance Européenne - EN203-1
Includes flame failure valve option
- Canadian Approval

INSTALLATION REQUIREMENTS & SHIPPING INFORMATION

- Technostar units must be installed in accordance with local codes or in their absence with the National Fuel Gas Code: ANSI Z223.1; Natural Fuel Gas Code: CAN/CGA-B149.1 or Propane Installation Code: CAN/CGA-B149.2, as applicable. Compliance with codes is the responsibility of the Owner and Installer.
- An adequate ventilation system is required. Refer to National Fire Protection Association Standard No. 96, "Standard for Ventilation and Fire Protection of Commercial Cooking Operations."
- This appliance is intended for commercial use by professionally trained personnel. NOT intended for Residential Use.
- Specify installation elevation: _____ if above 2000 feet (610m).
- GAS INLET SIZE:** 3/4" NPT at right rear. 3/4" NPT gas pressure regulator is provided. The gas supply pressure to the regulator must be 8"-14" WC for natural gas or 12"-14" WC for propane gas. Consult factory for different gas types and pressures.

Minimum Clearances	Combustible Construction	Noncombustible Construction
From Back Wall	T=2" (51mm) VT=5" (127mm)	T=0" VT=5" (127mm)
Left & Right Side	[T & VT] 11" (280mm)	[T & VT] 0"
T & VT Models with 6" (152mm) legs	Suitable for installation on combustible floors	
TC- Series for installation on noncombustible counters only.		

Specify Type of Gas:		<input type="checkbox"/> Natural	<input type="checkbox"/> Propane	Model Series	Shipping Class	Cube (Crated) ft ³ /m ³
Gas Manifold Pressure:		6.0" WC	10.0" WC			
Ovens/Tops:	Burners	BTU/hr* (kWh)	BTU/hr* (kWh)			
T26-Series*	1	35,000 (10.3)	35,000 (10.3)	T26-	85	26/.7
VT26-Series*	1	40,000 (11.7)	40,000 (11.7)	VT26-	85	26/.7
-6 top**	6	180,000 (52.8)	180,000 (52.8)	TC-	85	16/.5
-4-1FT top**	5	140,000 (41.1)	140,000 (41.1)			
-2-2FT top**	4	100,000 (29.3)	100,000 (29.3)			
-3FT top**	3	60,000 (17.6)	60,000 (17.6)			
*Add to Top BTU/hr firing rate, for TOTAL. **Total for: TC Models.				High shelf crated separately = 8 cu/ft (.2 m ³). Entry Clearance: T26 = 31-1/4" (794mm); VT26 = 34-1/4" (870mm).		
Unit Weight: See current Montague Price List						

Due to continuous product improvements, specifications are subject to change without notice.



THE MONTAGUE COMPANY
 1830 Stearman Avenue, Hayward, CA 94545
 800 345-1830 • Fax: 510 785-3342
 www.montaguecompany.com



MDR-2 [Rev. 08/11]