



MONTAGUE TECHNOSTAR

Medium-Duty

48" Restaurant Ranges

Item No. _____

Project _____

Quantity _____

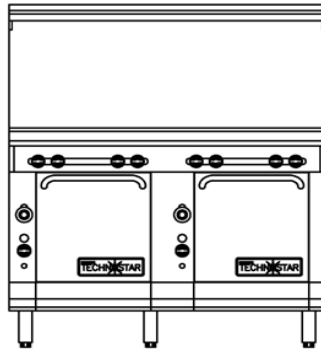

Model T1616-8

SHORT/BID SPECIFICATION

Range shall be a Montague *Technostar* Model: a 48" wide, gas heated medium-duty restaurant range mounted on [Specify Base Prefix]:

- T260-Series:** a 26-5/8" wide front-vented 35,000 BTU/hr conventional oven with heavy-duty door, porcelainized steel interior, four-position rack guides with two wire racks standard, positioned left; and a stainless steel open cabinet positioned right, with high-shelf/flue riser;
- VT260-Series:** a 26-5/8" wide front-vented 40,000 BTU/hr convection oven with heavy-duty door, porcelainized steel interior, five-position rack guides with three wire racks standard and high-shelf/flue riser;
- T1616-Series:** two 16-1/4" wide front-vented 20,000 BTU/hr half-size conventional ovens w/heavy-duty doors, porcelainized steel interiors, four-position rack guides w/one wire rack std with high-shelf/flue riser;
- T00-Series:** a double stainless steel open cabinet base with 6" legs and high-shelf/flue riser;
- TC-Series:** a stainless steel counter top base with 4" flue riser and 4" legs [Specify Top Suffix]:
- [-8] with eight 12" x 12.5" cast iron open top grates, over eight 30,000 BTU/hr cast iron burners, with individual burner controls and automatic standing pilots
- [-6-1FT] with six 12" x 12.5" cast iron open top grates, over six 30,000 BTU/hr star burners and one 12" wide 1/2" thick frytop with 20,000 BTU/hr burner, with individual burner controls and automatic standing pilots
- [-4-2FT] with four 12" x 12.5" cast iron open top grates, over four 30,000 BTU/hr star burners and one 24" wide 1/2" thick frytop with two 20,000 BTU/hr burners, w/individual burner controls and automatic standing pilots
- [-4-2FTB] with four 12" x 12.5" cast iron open top grates, over four 30,000 BTU/hr star burners and one 24" wide 1/2" thick frytop mounted over a broiler with three 18,000 BTU/hr cast iron burners, with individual burner controls and automatic standing pilots [on oven base only]
- [-2-3FT] with two 12" x 12.5" cast iron open top grate, over two 30,000 BTU/hr star burners and one 36" wide 3/4" thick frytop with three 20,000 BTU/hr burners, with individual burner controls and automatic standing pilots
- [-2-3FTB] with two 12" x 12.5" cast iron open top grate, over two 30,000 BTU/hr star burners and one 36" wide 3/4" thick frytop mounted over a broiler with four 18,000 BTU/hr cast iron burners, with individual burner controls and automatic standing pilots [on oven base only]
- [-4FT] with one 48" wide frytop with four 20,000 BTU/hr burners, with individual burner controls and automatic standing pilots...

...plus stainless steel front and sides and 4-5/8" deep front rail standard; plus all the features listed and options/accessories checked:

TECHNOSTAR TOP FEATURES:

Open Burner Sections are 12" wide x 27" deep with:

- Two-piece cast iron, surface-ground top grates over
- Two 30,000 BTU/hr cast iron star burners
- Automatic, standing pilots
- Drip pans positioned under burners

Frytops Sections (Griddle) are 12" wide [-2-1FT]; 24" wide [-2FT]; 36" wide [-3FT]; or 48" wide [-4FT]; and 24" deep, with:

- 1/2" thick precision-ground steel cook surface
- 2" high backsplash and tapered side-splashes
- 2-5/8" wide front grease gutter
- Built-in grease drawer
- One 20,000 BTU/hr gas burner with standing pilots & gas control valve, per 12" section
- Adjusting bolts for changing top plate forward pitch

Frytop/Broiler Combination [-2FTB & -3FTB]:

- Frytop section mounted right and raised 6" above broiler
- Over-fired broiler w/three [-2FTB] or four [-3FTB] 18,000 BTU/hr cast iron burners
- Roll-out broiler cooking grate, broiler burners also heat frytop

STANDARD OVEN FEATURES [T260 = FULL SIZE & T1616 = HALF SIZE]:

- 16-1/4" wide [T1616] or 26-5/8" [T260] and 26" deep x 14-1/4" high cooking compartment
- Front-venting oven design for more even cooking
- Heavy-duty counterweighted oven door — no springs
- Four position-adjustable nickel-plated rack supports, with one [T1616] or two [T260] racks standard
- Oven bottom and door porcelain lined for long life & easy cleaning
- Side & back liners are stainless steel
- 250-to-500°F (260°C) thermostat(s) mounted left of oven door(s)
- Two 20,000 BTU/hr [T1616] or one 35,000 [T260] cast iron burner with automatic ignition safety pilot

CONVECTION OVEN FEATURES [VT260]:

- 26-5/8" wide x 22-1/4" deep x 14-1/8" high cooking compartment
- Single speed motor with fan
- Front-venting oven design for more even cooking
- Heavy-duty counterweighted oven door — no springs
- Five-position adjustable nickel-plated rack supports, with three racks standard
- Oven bottom and door porcelain lined for long life & easy cleaning
- Side & Back liners are stainless steel
- 250-to-500°F (260°C) thermostat mounted left of oven door
- 40,000 BTU/hr cast iron burner with automatic ignition safety pilot

STANDARD CONSTRUCTION FEATURES:

- Satin finish stainless steel front and sides with 4-5/8" deep front rail [All models]
- 21-1/2" high-shelf is standard on T260-, T1616- & T00- Models
- Stainless steel 4" rear flue riser standard on TC- Models
- 6" adjustable stainless steel legs standard on T260, T1616- and T0- Models
- 4" legs standard on TC- Models
- 1" gas pressure regulator is provided as standard [All models]

AGENCY APPROVALS

- NSF Listed
- CSA Design Certified to ANSI Z83.11 • CSA 1.8
- CE Approved • EN 203-1



MDR-3 [Rev. 08/11]

THE MONTAGUE COMPANY • 1830 Stearman Avenue, Hayward, CA 94545 • 800 345-1830 • Fax: 510 785-3342 • montaguecompany.com



Item No. _____
 Project _____
 Quantity _____

Medium-Duty 48" (1219mm) Restaurant Ranges

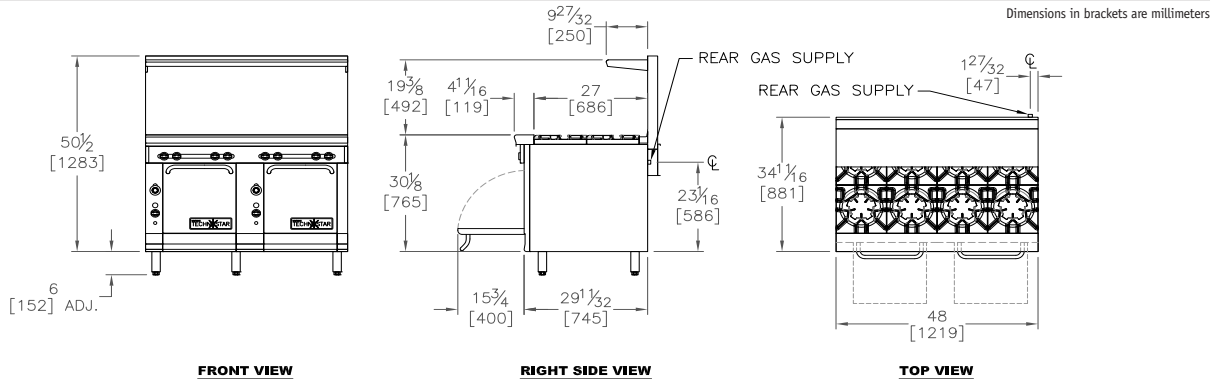

OPTIONS GUIDE:

For Frytop Sections:

- 3/4" (19mm) thick plate
- 1" (25mm) thick plate - Not available on -1FT
- Thermostat control(s) [Add to Suffix: -FTT]
- 4" (102mm) removable side splash:
 - left right
- Frytop/Broiler [Add to Suffix: -FTB]
- Substitute Work Top for Open Burners**
 Use Suffix: -_WS [Specify number: 1 - 4]

Controls:

- Flame failure rangetop safety valves

For Ovens:

- Extra oven racks: ____ea.
 - 3/4 HP fan motor [VT260 Models]
 - 208/240-volt power connection [VT260 Models]
- #### Flue Risers [In Lieu of High Shelf]:
- 4" (102mm) high riser:
 - 21-1/2" (546mm) high riser

Finish:

- Stainless steel back panel
- Stainless steel bottom shelf [T0 Models]

General:

- Casters — set of six 5" (127mm) casters
- Curb Mounting — Non combustible floors only
- Flex Connector Kit** [3/4" (19mm)]
 - 3" (910mm) 4" (1219mm)

International Approvals:

- CE - Conformance Europeenne - EN203-1
Includes flame failure valve option
- Canadian Approval

INSTALLATION REQUIREMENTS & SHIPPING INFORMATION

- Technostar units must be installed in accordance with local codes or in their absence with the National Fuel Gas Code: ANSI Z223.1; Natural Fuel Gas Code: CAN/CGA-B149.1 or Propane Installation Code: CAN/CGA-B149.2, as applicable. Compliance with codes is the responsibility of the Owner and Installer.
- An adequate ventilation system is required. Refer to National Fire Protection Association Standard No. 96, "Standard for Ventilation and Fire Protection of Commercial Cooking Operations."
- This appliance is intended for commercial use by professionally trained personal. NOT intended for Residential Use.
- Specify installation elevation: _____ if above 2000 feet (610 m).
- GAS INLET SIZE:** 1" NPT at right rear. 1" NPT gas pressure regulator is provided. The gas supply pressure to the regulator must be 8"-14" WC for natural gas or 12"-14" WC for propane gas. Consult factory for different gas types and pressures.

Minimum Clearances	Combustible Construction	Noncombustible Construction
From Back Wall	T=2" (51mm) VT=5" (127mm)	T=2" (51mm) VT=5" (127mm)
Left & Right Side	[T & VT] 11" (279 mm)	[T & VT] 2" (51 mm)
T & VT Models with 6" (152 mm) legs	Suitable for installation on combustible floors	
TC- Series for installation on noncombustible counters only.		

Specify Type of Gas:		<input type="checkbox"/> Natural	<input type="checkbox"/> Propane	Model Series	Shipping Class	Cube (Crated) ft ³ /m ³
Gas Manifold Pressure:		6.0" WC	10.0" WC			
Ovens/Tops:	Burners	BTU/hr* (kWh)	BTU/hr* (kWh)			
T260-Series*	1	35,000 (10.3)	35,000 (10.3)	T260-	85	35/1
VT260-Series*	1	40,000 (11.7)	40,000 (11.7)	VT260-	85	35/1
T1616-Series*	2	40,000 (11.7)	40,000 (11.7)	T1616-	85	35/1
-8 top**	8	240,000 (70.3)	160,000 (46.9)	T00-	85	35/1
-6-1FT top**	7	200,000 (58.6)	140,000 (41)	TM-	85	21/.6
-4-2FT top**	6	160,000 (46.9)	120,000 (35.2)	TC-	85	16/.5
-2-3FT top**	5	120,000 (35.2)	100,000 (29.3)	High shelf crated separately = 8 cu/ft (.2 m ³). Entry Clearance: T26 = 31-1/4" (79.4 cm); VT26 = 34-1/4" (87 cm).		
-4FT top**	4	80,000 (23.4)	80,000 (23.4)	Unit Weight: See current Montague Price List		
*Add to Top BTU/hr firing rate, for TOTAL. **Total for: T00, TC Models.						
Add 12,000 BTU/hr (3.5 kWh) for -3FTB or 14,000 BTU/hr (4.1 kWh) for -2FTB Broiler option						



THE MONTAGUE COMPANY

1830 Stearman Avenue, Hayward, CA 94545
 800 345-1830 • Fax: 510 785-3342
 www.montaguecompany.com

Due to continuous product improvements, specifications are subject to change without notice.



MDR-3 [Rev. 08/11]