















MOFFAT® G32MSW/2 Double Stacked **Full Size Gas Convection Ovens**

-  Robust stainless steel exterior for long life
-  Porcelain inner for easy cleaning and durability
-  Stainless steel door with large viewing window for extra visibility
-  Door is field reversible for line end positioning
-  Stay cool heavy duty stainless steel door handle
-  4 full sheet pan capacity (6 with optional cookie kit)
-  High efficiency infra-red burners for faster heating and less gas consumption
-  Low fan velocity eliminates need for 2 speed fan
-  Easy to use mechanical controls
-  60 minute timer for baking
-  3 hour roasting timer with cook n hold system
-  Internal lighting
-  Water injected steam (hook-up optional)
-  Compact footprint – only 28" x 32"
-  Quiet in operation – can be used front of house



G32MSW/2 Double Stacked



Order Toll Free 1800 551 8795

G32MSW/2 Double Stacked

Units shall be Moffat gas heated low velocity Turbofan convection ovens NSF listed (NSF-4), CSA (AGA) ANSI Z83.11-2002/CSA 1.8-2002 double stacked on a specially designed stacking kit. Each oven shall have a one piece vitreous porcelain enamel oven liner, stainless steel top and sides with single stainless steel door and full size viewing window. Each door shall be field reversible. Each oven liner shall be insulated on all sides and have capacity for 4 full size sheet pans or 6 with cookie kit option. The oven temperature shall be controlled by a mechanical thermostat and shall have a bake timer, roast timer, cook 'n hold system and feature water injection for optional connection. Each oven shall be fitted with a NEMA 5-15P cordset.

MOFFAT® G32MSW/2 Double Stacked Full Size Gas Convection Ovens

MOFFAT®
www.moffat.com

CONSTRUCTION

Stainless steel top and sides
Enamel oven interior
Field reversible door
Toughened twin pane door window glass
Full stainless steel door handle
4 pan capacity (4 wire oven racks included)
Fully insulated
Fully enclosed motor

CONTROLS

On/off switch
Mechanical thermostat, variable between 150°F to 600°F
1 hour bake timer with buzzer
3 hour roast timer
Cook n hold factory preset at 158°F (range 140°F to 194°F)
Water injection steam (momentary switch)
Low velocity fan system
2 oven lights
Infra-red burner system

CLEANING AND SERVICING

Easy clean stainless steel and enamel surfaces
Fully removable racks and baffle
Access to all controls from front panel
Full access side service panel
Removable door seals

OPTIONS

Cookie Kit
E89 Proofer and Holding Cabinet
Full range of 18" x 26" pans
Chicken racks

SPECIFICATIONS

Gas Rating (each oven)
35 MJ/hr, 33,000 Btu/hr
Gas Inlet (each oven)
1/2" female NPT
Electrical requirements (each oven)
110-120V, 60Hz, 0.24kW, 1P+N+GND
Nema 5-15P cord set fitted

Water (each oven)
3/4" thread
80psi max inlet pressure
20psi min inlet pressure



External Dimensions
Width 28" (710mm)
Height 68 7/8" (2181mm)
Depth 33 1/4" (845mm)

Internal Dimensions (each oven)
Width 18" (460mm)
Height 20 1/2" (520mm)
Depth 26" (660mm)

Oven Rack Dimensions (each oven)
Width 18" (460mm)
Depth 26" (660mm)
Between racks 5" (125mm)
3" (75mm) with cookie kit

Nett Weight (total)
507lbs (230kg)

Packing Data (each oven)
353lbs (160kg)
23ft³ (0.65m³)
Width 29 1/2" (750mm)
Height 36 1/2" (925mm)
Depth 37 1/4" (945mm)

Packing Data (stacking kit)
19lbs (8.5kg)
0.78 ft³ (0.022m³)
Width 9 5/8" (245mm)
Height 3 3/4" (95mm)
Depth 36 5/8" (930mm)

Clearances
Left side 3" (75mm)
Right side 3" (75mm)*
Rear 3" (75mm)
Top 8" (200mm)

*Fixed installations require at least 500mm(20") clearance at RHS for serviceability.

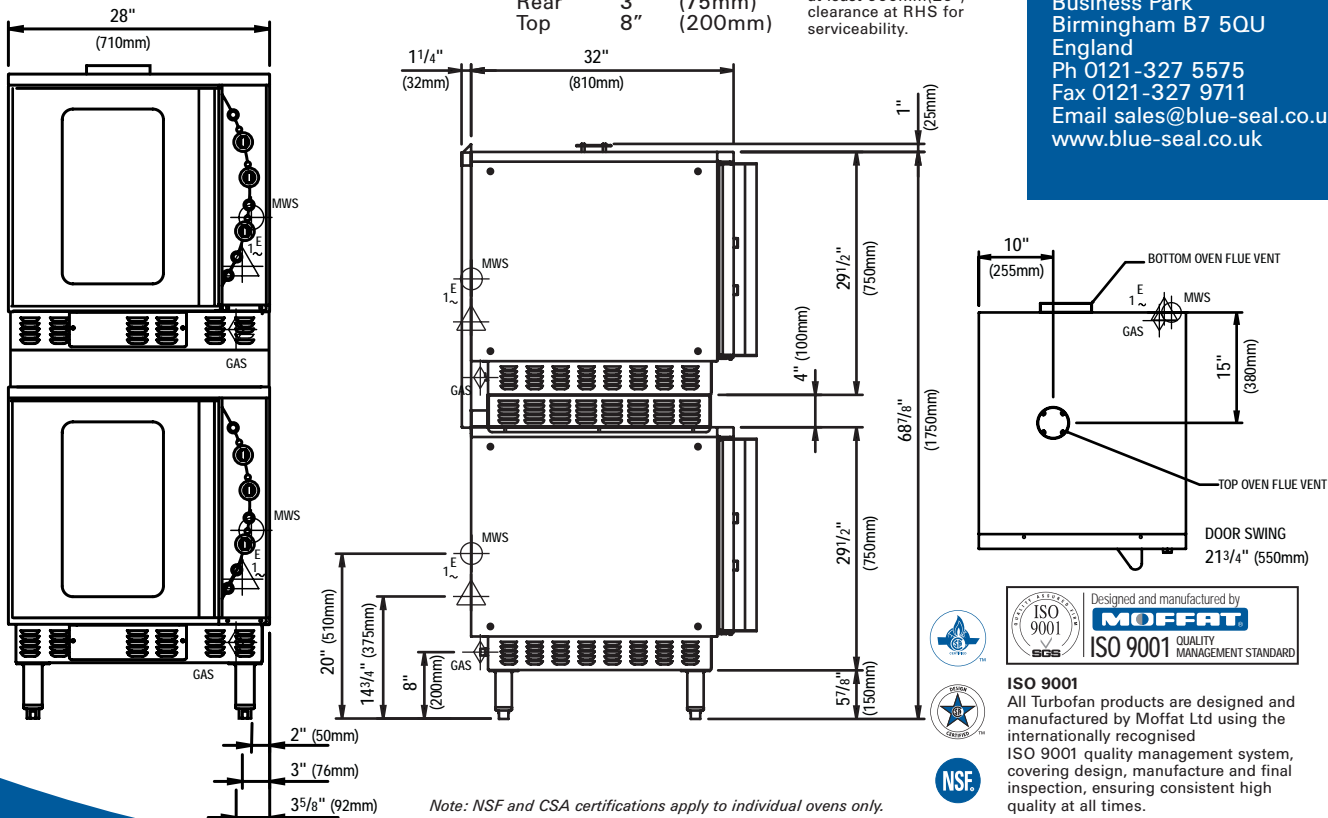

U.S.A

Moffat Inc
3765 Champion Boulevard
Winston-Salem
North Carolina 27105
Call Free 1800 551 8795
Ph 336-661 0257
Fax 336-661 9546
Email sales@moffat.com
www.moffat.com

Canada

Serve Canada
22 Ashwarren Road
Downview
Ontario, M3J 1Z5
Ph 416-631 0601
Fax 416-631 0315
Email info@servecanada.com

Australia

Moffat Pty Limited
740 Springvale Rd
Mulgrave
Victoria 3170
Australia
Ph 03-9518 3888
Fax 03-9518 3833
Email vsales@moffat.com.au
www.moffat.com.au

New Zealand

Moffat Limited
16 Osborne St
PO Box 10-001
Christchurch
New Zealand
Ph 03-389 1007
Fax 03-389 1276
Email sales@moffat.co.nz
www.moffat.co.nz

United Kingdom

Blue Seal Limited
Units 6-7 Mount St
Business Park
Birmingham B7 5QU
England
Ph 0121-327 5575
Fax 0121-327 9711
Email sales@blue-seal.co.uk
www.blue-seal.co.uk

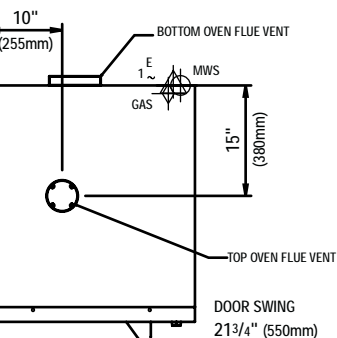

ISO 9001
All Turbofan products are designed and manufactured by Moffat Ltd using the internationally recognised ISO 9001 quality management system, covering design, manufacture and final inspection, ensuring consistent high quality at all times.

