

ELECTRIC FRYERS 40 LB. MODELS

IMPERIAL®

Model Numbers
IFS-40-E IFS-40-EU



Immersed element models are the lowest cost alternative for electric fryers.



Tilt-up elements provide full access to the frypot for cleaning.

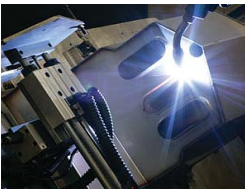

Robotic welding is precise, virtually eliminating leaks.



Stainless steel exterior (except back) is easy to clean and has a professional look.



IFS-40-E shown

ELECTRIC ELEMENTS - Elements are located inside the stainless steel frypot, below the fry zone.

- Element output is 14 KW.
- Two elements styles are available, immersed elements are the most economical, the tilt-up elements offer complete access to the frypot for cleaning.
- Direct heat-to-element contact heats oil quickly resulting in less absorption and better tasting food.
- Snap acting electronic thermostat has a 200°F - 400°F. (93°C - 204°C) temperature range that extends oil life and produces a uniformly cooked product.

LARGE COOL ZONE - Captures and holds particles out of the fry zone.

- Reduces taste transfer.

STAINLESS STEEL FRYPOTS - Large 14" x 14" (356 x 356 mm) frying area.

- Frypot sides are robotically welded stainless steel to virtually eliminate leaks.
- Fine mesh wire crumb is included.
- Deep drawn bottom facilitates draining, slants toward the drain.
- 1-1/4" (32 mm) full port drain valve empties frypot quickly and safely.
- Two large, nickel-plated fry baskets with vinyl coated, heat protection, handles are included.
- Basket hangers are stainless steel.

EXTERIOR FEATURES - Stainless steel front, door, sides, basket hanger and frypot.

- Welded and polished stainless steel seams.
- Full heat shield protects control panel.
- Full bottom chassis provide structural support.
- Plate mounted 6" (152 mm) heavy duty stainless steel legs or optional casters assure secure support.
- One year parts and labor warranty. Limited warranty on frypot, stainless steel frypot is five years pro-rated.



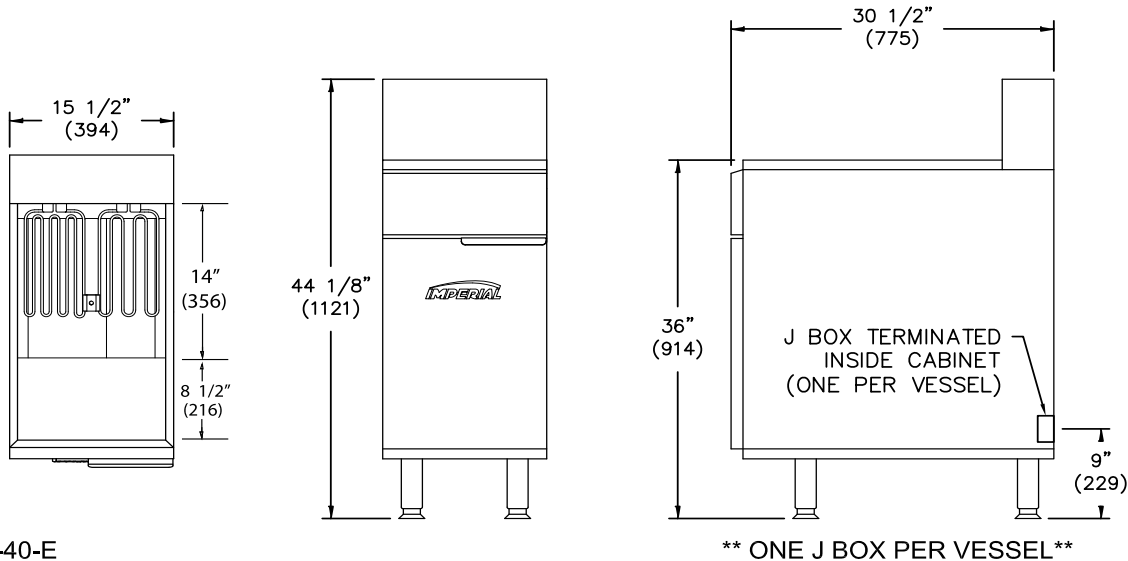

IFS-40-E

** ONE J BOX PER VESSEL **

40 LB. ELECTRIC FRYERS

MODEL	OIL CAPACITY	TOTAL OUTPUT	SHIP WEIGHT (KG)	LBS
IFS-40-E	40 lbs (22 L)	14 KW	(100)	221
IFS-40-EU	40 lbs (22 L)	14 KW	(100)	221
IFS-DS	N/A, drain station	N/A	(60)	130

Measurements in () are metric equivalents.

NOTES

- "DS" drain station with storage cabinet, no filter. Includes a 4" (102 mm) deep stainless steel drain pan

CLEARANCE REQUIREMENTS

For use only on non-combustible floors. Legs or casters are required for non-combustible floors; or 2" (51 mm) overhang is required when curb mounted. Provide 0" clearance from non-combustible surfaces and 6" (152 mm) from combustible surfaces.

OPTIONS AND ACCESSORIES

- Fryer drain station with storage cabinet
- Heat lamp for drain station
- Stainless steel joiner strips
- 20-1/2" (521 mm) high backguard, no shelf
- Automatic basket lifts
- Computer controls
- Manual timer
- Catering package for easy transporting
- Extra fry baskets with vinyl coated handles
- 6" (152 mm) casters

MODEL	WORKING WIDTH	WORKING DEPTH	FRYING AREA	DIMENSIONS	CRATED DIMENSIONS
IFS-40-E	15-1/2" (394 mm)	30-1/2" (775 mm)	14" x 14" (356 x 356 mm)	15-1/2" w x 30-1/2" d x 44-1/8" h (394 x 775 x 1121 mm)	18" w x 34" d x 35" h (457 x 864 x 889 mm)
IFS-40-EU	15-1/2" (394 mm)	30-1/2" (775 mm)	14" x 14" (356 x 356 mm)	15-1/2" w x 30-1/2" d x 44-1/8" h (394 x 775 x 1121 mm)	18" w x 34" d x 35" h (457 x 864 x 889 mm)
IFS-DS	15-1/2" (394 mm)	30-1/2" (775 mm)	N/A	15-1/2" w x 30-1/2" d x 44-1/8" h (394 x 775 x 1121 mm)	18" w x 34" d x 35" h (457 x 864 x 889 mm)

ELECTRIC AMPERAGE REQUIREMENTS

MODEL	TOTAL KW	VOLTAGE	PHASE	AMPS
IFS-40-E, IFS-40-EU	14 KW	208	3	38.91
	14 KW	240	3	33.72



E-14 11/13 © 2013 Imperial Commercial Cooking Equipment

1128 Sherborn Street Corona, CA 92879
800.343.7790 Ph: 951.281.1830 Fx: 951.281.1879
www.imperialrange.com
E-mail: imperialsales@imperialrange.com

All specifications subject to change without notice. Printed in the U.S.A.

Imperial reserves the right to change specifications at any time without prior notice and without any obligation for past or future equipment purchases. Visit www.imperialrange.com for specification updates.