

Project _____

Item # _____

Quantity _____



GLOBE FOOD EQUIPMENT COMPANY

Manual Slicer

4600P



4600P Manual Slicer

Protech™ Model

- 4600P - Manual Slicer

Features a 13" PreciseEdge™ knife, a premium gear drive system, and Globe's exclusive EZ-Glide™ table.

Standard Features

- 13" *PreciseEdge™* hardened steel alloy knife
- Premium gear driven knife
- Maintenance-free drive system
- Powerful 1/2 HP, 7 amp motor
- Exclusive stainless steel construction
- Built in antimicrobial protection
- Precision gear slice thickness adjustment
- *EZ-Glide™* adjustable slicing table
- Table lockout
- Open space base design
- Knife cover interlock
- Signature knife sharpening system
- Permanently attached knife ring guard
- Home position start
- Automatic shut off
- Full gravity feed, 45° angle
- 3 lb. stainless steel end weight
- Cleaning brace
- Touch pad controls
- Power indicator light
- No voltage release

Options and Accessories

- Teflon® coating (knife, knife cover, table)
- Frozen meat slicing package (includes a serrated knife and bronze gear)
- Front mounted end weight assembly
- Unique dual arm lift lever
- Prison package
- High moisture application package (includes stainless steel knife)
- 15" long food chute
- Aluminum food chute
- Stainless steel knife
- End weight with meat prongs
- Low food fence (12"L x 1 3/8"H)
- High food fence (12"L x 3"H)
- 3" extension legs
- 10 lb. attachable portion control scale
- Vegetable hopper
- Clear plastic slicer cover



Made in the U.S.A.



Standard Warranty

- 2 years parts and 1 year labor plus 15 years on the knife drive gears

Approved By: _____

Date: _____



GLOBE FOOD EQUIPMENT COMPANY

www.globeslicers.com

2153 Dryden Rd.
Dayton, OH 45439
Phone: 937-299-5493
Phone: 800-347-5423
Fax: 937-299-4147



Specifications

Finish: Exclusive all stainless steel base with radiused corners improves sanitation and durability. Other stainless steel parts include the food chute, slicing table, end weight, and knife cover.

Knife Motor: Powerful 1/2 HP, 7 amp, 115/60/1, air cooled, permanently lubricated sealed ball bearings. Solid state start relay.

Knife Drive: Cross axis helical gear drive design. This maintenance free drive design is continuously lubricated ensuring quiet operation and reliable cutting performance.

Slice Thickness: Precision dual gear design eliminates table movement during slicing. Consistently produces tissue thin slices with a maximum slice thickness of 1 1/4" thick.

Antimicrobial Protection: Knobs and handles have antimicrobial protection built in, which inhibits the growth of bacteria and provides superior sanitation.

Full Gravity Feed: Full 45° angle feed requires less mechanical pressure. Equipped with a 3 lb. stainless steel end weight to minimize waste and hold product. Food chute handle is ergonomically designed and the end weight swings away for storage behind the chute.

Table: EZ-Glide™ adjustable slicing table is designed to reduce surface friction, facilitating a smooth and easy slicing stroke.

Home Position Start: Food chute must be pulled to the position closest to the operator to start the slicer. This forces the operator to follow proper operating procedures.

Cleaning Brace: A metal brace under the slicer drops into position, tilting the slicer to facilitate safe and easy cleaning underneath the slicer.

Table Lockout: Once the table is closed and the knife cover is removed, the table cannot be opened. The table fully covers the knife's cutting edge protecting the operator during cleaning.

Knife Cover Interlock: Slicer will not operate with knife cover removed.

Automatic Shut Off: Slicer automatically shuts off after 10 seconds of no chute movement.

Knife Ring Guard: Permanently mounted knife ring guard covers the non-slicing portion of the knife protecting the operator from the knife's edge.

Top Mounted Sharpener: Metal knife sharpener is permanently mounted on the slicer. A single lever activates the stones to quickly and easily return a razor sharp cutting edge.

Hollow Ground Knife: 13" diameter special hardened steel alloy knife with stain resistant finish and sanitary hub provides increased cutting capacity, clean cuts, and effortless slicing. Knife's edge has a Rockwell hardness of 60-62.

No Voltage Release: Prevents inadvertent reactivation of slicer in the event of power or interlock interruption.

Cutting Capacity: Width 11.6" (29.5cm), Height 9" (22.9cm), Diameter 7.5" (19cm)

Touch Pad Controls: Smooth moisture proof start/stop touch pad controls provide exceptional reliability and are simple to clean and operate.

Power Indicator Light: A readily visible red light illuminates when the knife is rotating.

Cord & Plug: Attached 7 foot flexible 3 wire cord with molded plug fits a grounded receptacle.

Dimensions:

Foot Print = 14" x 21.6"
(35.6 cm x 54.9 cm)
Overall Length = 26.2" (66.5 cm)
Overall Width = 22" (55.9 cm)
Overall Height = 21.1" (53.6 cm)
Freight Class: 77.5
Net Weight: 112 lbs. (50.8 kgs.)
Shipping Weight: 140 lbs. (63.5 kgs.)
Shipping Dimensions:
28"W x 25"D x 28"H
(71.1cm x 63.5cm x 71.1cm)

Factory Installed Options:

TEFLON®	Teflon® coating (coated knife, knife cover, table)
FROZEN	Frozen meat slicing package
FMEW	Front mounted end weight
LEVER	Dual arm lift lever
PRISON	Prison package
MEATROOM	High moisture application package
LONGCHUTE	15" long food chute
ALUM	Aluminum food chute
SSK	Stainless steel knife
PRONGS	End weight with meat prongs

Accessories:

1326	High fence (12" x 3")
1047	Low fence (12" x 1 3/8")
873-SET	3" extension legs
PS13	10 lb. attachable portion control scale
699-BAS	Vegetable hopper
SC-GLOBE	Clear plastic slicer cover

Teflon® is a registered trademark of DuPont.

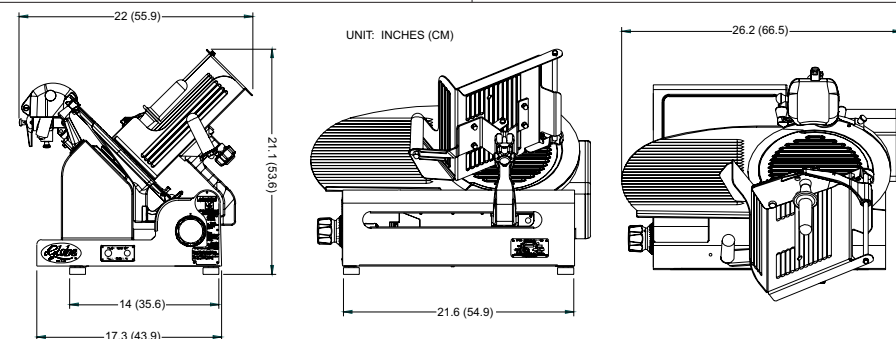

GLOBE FOOD EQUIPMENT COMPANY

www.globeslicers.com

2153 Dryden Rd.
Dayton, OH 45439
Phone: 937-299-5493
Phone: 800-347-5423
Fax: 937-299-4147

Printed in U.S.A. 6-2007