



Item: \_\_\_\_\_  
 Quantity: \_\_\_\_\_  
 Project: \_\_\_\_\_  
 Approval: \_\_\_\_\_  
 Date: \_\_\_\_\_

# SCO Series Gas Convection Oven

SCO Series Gas Convection Oven

Models:

- SCO-GS-10S       SCO-GS-20S



SCO-GS-10S

Note: Ovens supplied with casters must be installed with an approved restraining device.

Standard Features:

- SUNFIRE Series Solid State control with electro-mechanical timer
- Direct spark ignition with 100% safety shutoff
- Single speed fan control with 3/4 HP fan motor
- Total of 53,000 BTU (15.53 kW) loading per oven cavity
- Natural or propane gas
- Stainless steel front, sides, top, and legs
- 60/40 dependent solid door design
- Porcelain enameled oven interior with coved corners
- Five (5) chrome plated ovens racks on 10-position rack guides
- Double deck models available.
- One year limited parts and labor warranty (USA and Canada only)
- Three year limited door warranty (USA and Canada only)

Optional Features:

- Two speed fan
- Two speed fan with windows in left door and interior oven lights.
- Extra oven racks
- Swivel casters, (4) w/ front brakes
- Low profile casters, (4) w/ front brakes (double ovens only)
- Open base with rack guides and shelf (stainless steel)
- Direct connect vent
- Gas flex hose w/quick disconnect & restraining device
- Back enclosure (stainless steel)

Specifications:

SUNFIRE Full-Size Standard Depth gas convection oven. 53,000 BTU/hr (15.53)/cavity, 3/4 HP single-speed fan motor. Direct spark ignition. Natural gas or propane. Solid State Control with 60-minute timer. 115 volt single phase, 60 Hz. Porcelain enameled oven interior with coved corners, five (5) oven racks and 10 position rack guides. All model interiors are 29" (736mm) wide by 24" (610mm) deep. Stainless steel front, sides, top and legs. 60/40 dependent solid door design. Models with the 20S suffix are double deck units. UL, CUL Gas-Fired and NSF listed.



Garland Commercial Ranges Ltd.  
 1177 Kamato Road,  
 Mississauga, Ontario  
 L4W 1X4 CANADA

General Inquiries 1-905-624-0260  
 USA Sales, Parts and Service 1-800-424-2411  
 Canadian Sales 1-888-442-7526  
 Canada or USA Parts/Service 1-800-427-6668





SCO Series Gas Convection Oven

Model	Int. Dimensions : In (mm)			Ext. Dimensions: In (mm)			Ship Wt	Ship Dim.
	W	H	D	W	H**	D (w/motor)	Lbs/kg	Cubic Ft.
SCO-GS-10S	29 (736)	24 (610)	24 (610)	38 (965)	57-1/2 (1461)	41-1/4 (1048)	750/341	80
SCO-GS-20S	29(736)	24(610)	24(610)	38(965)	70-1/2 (1791)	41-1/4 (1048)	1500/682	160

\*\* Height with or without standard casters. Height with low profile casters (double deck) is 68-1/2" (1740mm).

Models	Input Ratings, Natural & Propane			Operating Pressure *		Electrical Specifications
	BTU/hr	kW Equiv.	Gas Inlet	Natural	Propane	120V/1Ph.
Single Deck	53,000	15.53	(1) @ 3/4" NPT	4" WC	10" WC	(1)@9.8A
Double Deck	106,000	31.06	(1) @1" NPT	(10 mbar)	(25 mbar)	(2)@9.8A

\*Maximum Pressure 13.8" WC @ 70°F (21°C)

Many local codes exist and it is the responsibility of the owner and installer to comply with those codes. These appliances are intended for commercial use by professionally trained personnel.

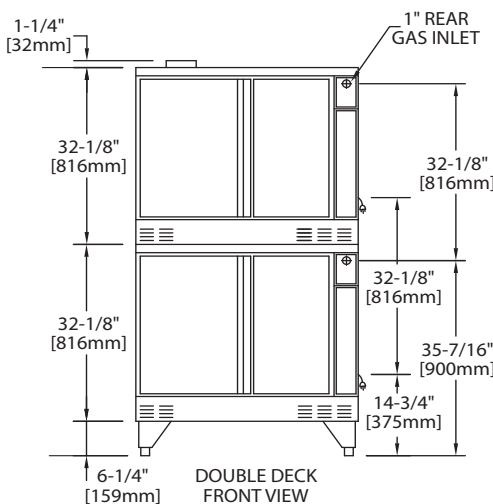
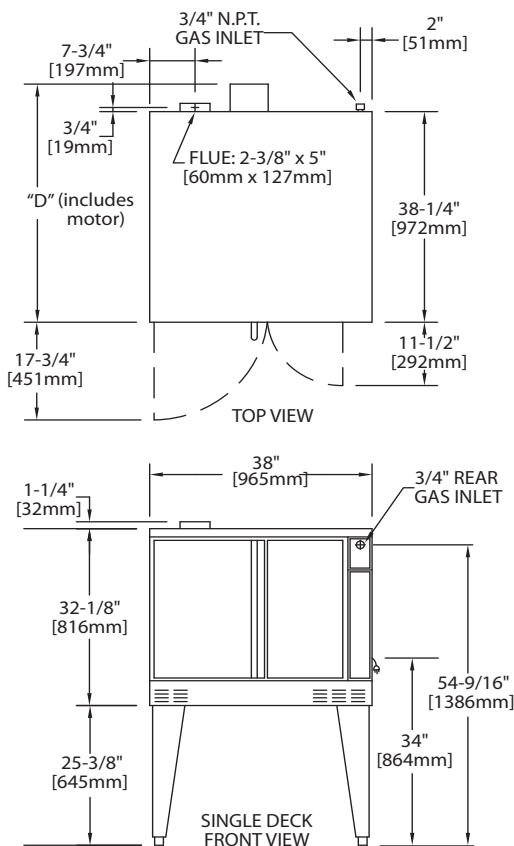

Installation Notes:			
Combustible & Non-Combustible Wall Clearances:			
Sides	1" (25mm)	Back	3" (76mm)
Entry Clearances: In (mm)			
Crated	44-1/2 (1130)	Uncrated	32-1/2 (826)

**Notes:**

- Standard electrical specifications include motor requirements.
- (120V units) 115V, 3/4 HP, 1725 rpm; 2-speed motor option, 1140 and 1725 rpm, 60Hz.
- A 6 ft. line cord is provided for each 120V deck with a (NEMA #5-15P) plug.
- It is recommended a separate 15 AMP circuit for each 120V unit.

Form# SCOGS (06/22/12)

Garland Commercial Ranges Ltd.  
1177 Kamato Road,  
Mississauga, Ontario  
L4W 1X4 CANADA

General Inquiries 1-905-624-0260  
USA Sales, Parts and Service 1-800-424-2411  
Canadian Sales 1-888-442-7526  
Canada or USA Parts/Service 1-800-427-6668

